

2.2 Two-Axle Shuttle (Rear Axle Empty)	2
2.2.01 Directives Complied with by the Shuttle	2
2.2.02 Description of Function	2
2.2.02.1 Running Commands of the Control Cams.....	2
2.2.02.2 Running Commands of the Optoelectronic Distance Sensor.....	3
2.2.02.3 Running Commands by Switching the Drive Current On or Off	4
2.2.03 Technical Data	4
2.2.04 Load Limits	5
2.2.04.1 Load Capacity	5
2.2.04.2 Location of the Center of Gravity (Fig. 2.2-4)	5
2.2.04.3 Static Moment around the Longitudinal Axis (Fig. 2.2-4)	5
2.2.04.4 Safe Forces and Moments on the Shuttle Platform	6
2.2.05 Hazards	7
2.2.05.1 Environment	7
2.2.05.2 Location of the Center of Gravity.....	7
2.2.05.3 Risk of Squeezing on Manual Workstations with Positioning Device	7
2.2.06 Installation	8
2.2.07 Disassembly	8
2.2.08 Troubleshooting	9
2.2.09 Problem Elimination	10
2.2.09.1 Replacing the "Front Axle" (10, Fig. 2.2-11)	10
2.2.09.2 Replacing the Distance Sensor (50, Fig. 2.2-8)	10
2.2.09.3 Replacing the PLC (Fig. 2.2-9).....	11
2.2.09.4 Replacing the Current Collector (Fig. 2.2-10)	11
2.2.10 Maintenance	12
2.2.10.1 Cleaning the Lens	12
2.2.10.2 Checking the Rear Cover	12
2.2.10.3 Checking the Track Rollers	12
2.2.10.4 Checking the Housing.....	12
2.2.10.5 Checking the Carrying Rollers	12
2.2.10.6 Checking the Sensors	12
2.2.10.7 Checking and Cleaning the Current Collectors.....	12
2.2.10.8 Cleaning the Shuttle	12
2.2.11 Exploded Views	13
2.2.11.1 Shuttle, Complete	13
2.2.11.2 Axle, Front	14
2.2.11.3 Axle, Rear.....	15
2.2.11.4 Current Collector, Item No. 91166	16
2.2.12 Environmental Friendliness and Disposal	16
2.2.12.1 Materials Used.....	16
2.2.12.2 Surface Treatment	17
2.2.12.3 Forming Processes.....	17
2.2.12.4 Emission during Operation.....	17
2.2.12.5 Disposal	17

2.2 Two-Axle Shuttle (Rear Axle Empty)

2.2.01 Directives Complied with by the Shuttle

The complied-with directives apply to all operating modes, which can occur in a Montrac transportation system, and to all functions that a shuttle must fulfill based on the description.

- **Machine Directive:** 98/37/EWG.

2.2.02 Description of Function

The shuttle is a vehicle that runs in a closed monorail system for the purpose of material transportation.

It is driven by a controllable low-voltage motor that is powered via four carbon rollers each by the power strips located on the sides of the monorail (track).

The running operation is achieved in three ways:

2.2.02.1 Running Commands of the Control Cams

Fig. 2.2-1

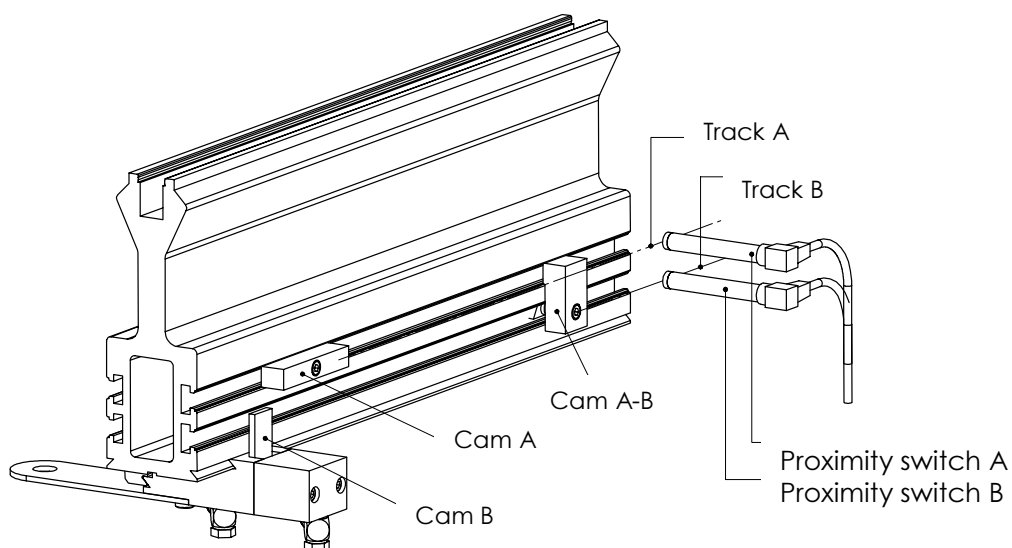

The two proximity switches **A** and **B** run along track **A** or **B** and pass the cams at a distance of approx. 1.5 mm; they affect the following running commands:

- Cams A-B shuttle speed 12 m/min.
- Cam A regulates shuttle speed from 12 m/min. to zero
- Cam B* starts shuttle and accelerates to 30 m/min.

* The start cam can be moved with a pneumatic cylinder, so that it can be set active or inactive. If a movable A-B cam is used instead of a movable B-cam, the shuttle is only accelerated to 12 m/min. after the start.

If the A-cam is mounted in the B-track, the shuttle speeds to 30 m/min.

2.2.02.2 Running Commands of the Optoelectronic Distance Sensor

Fig. 2.2-2

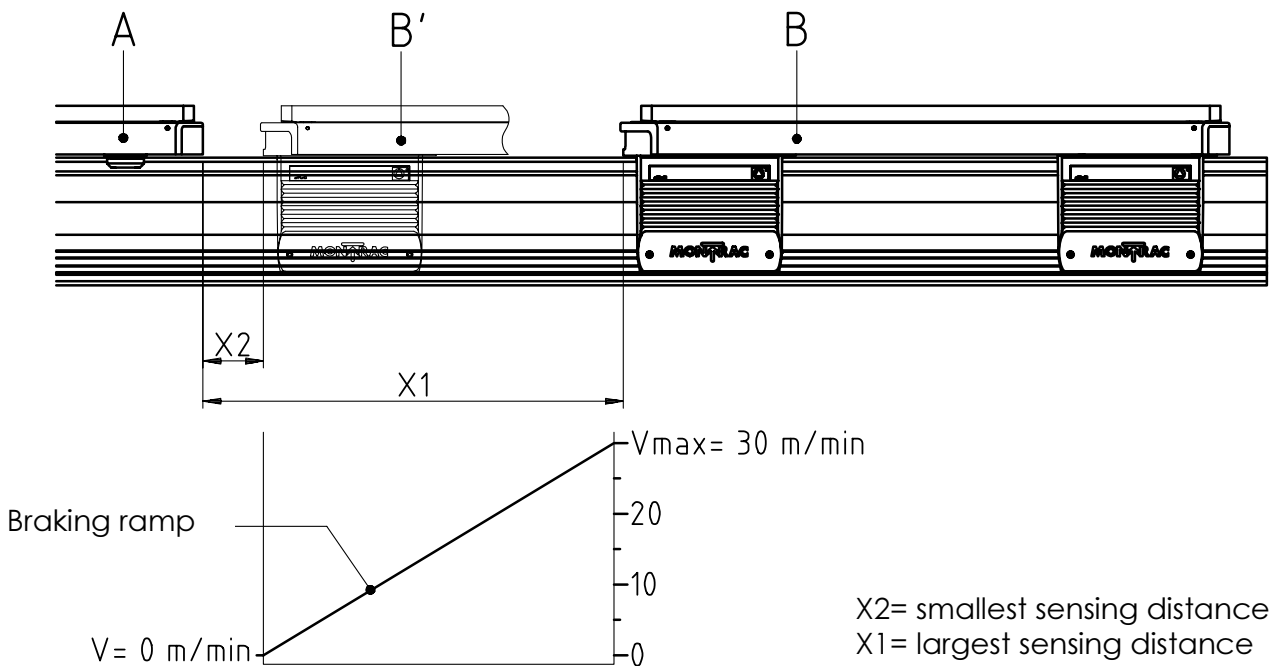

If an obstacle (A), e.g., a standing shuttle, is identified to be at a distance X_1 from a shuttle (B) going 30 m/min., the latter lowers its speed to zero and stops at a distance X_2 behind (A) (position B').

If the obstacle disappears from the recognition horizon of the distance sensor, the shuttle accelerates back up to the speed it had before sensing the obstacle.

$X_1 = 350 - 450 \text{ mm}$

$X_2 = 80 - 120 \text{ mm}$ (depending on the load situation of the shuttle)

2.2.02.3 Running Commands by Switching the Drive Current On or Off



In each case, the following sequence shall be followed during start-up:

1. Power supply of the system PLC (no voltage on the power strips!)
2. Switch on the pneumatics/hydraulics system
3. Do not actuate any valves. (Caution: some elements require bi-stable, others mono-stable valves. For further information see the technical documentation).
4. Power supply of the power strips.
5. 6 sec. waiting time. During this time, all presence check signals should be ignored.
6. Start the automatic cycle.

When a Montrac line is switched off – regardless of whether it is a "normal stop" or an "emergency stop" – the shuttles can assume any position.

2.2.03 Technical Data

Two-axle shuttle length		550 mm
Stop precision (with A-cams)		± 1.0 mm
Maximum running speed V_{max}		30 m/min
Reduced running speed V_{red}		12 m/min
Total weight		17 kg
Shuttle weight without platform		6.2 kg
Supply voltage		24 V DC
Current consumption	when stopped	0.08 A
	at V_{max}	0.80 A
	when accelerating	2.24 A
Permissible current consumption of an additional		
Acceleration time	without load *	0.85 s
	with max. load *	1.40 s
Sound pressure level		< 59 dB (A)
Environment:	permissible temperature range	10-40 °C
	air purity level	atmosphere for the assembly of fine mechanical products
	relative humidity	≤ 90% without formation of condensation

* until $0.95 \times V_{max}$ is reached

2.2.04 Load Limits

2.2.04.1 Load Capacity

Fig. 2.2-3

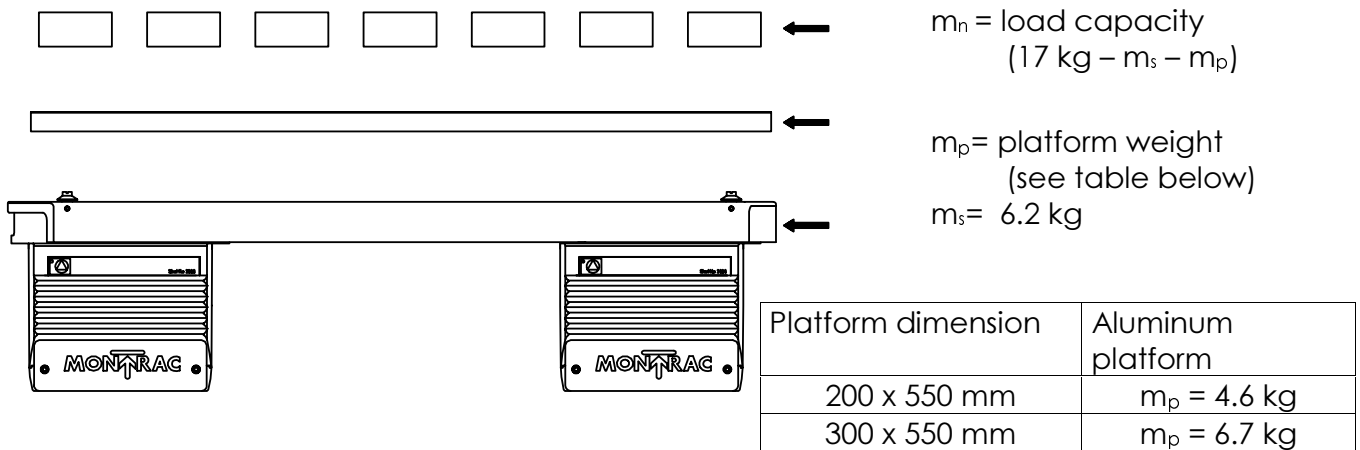

2.2.04.2 Location of the Center of Gravity (Fig. 2.2-4)

The center of gravity (S) of the load capacity (m_n) must be located within the shaded area.

2.2.04.3 Static Moment around the Longitudinal Axis (Fig. 2.2-4)

(This moment must not be exceeded outside of the positioning device)

$$M_s = m_n \cdot 9.81 \text{ msec}^{-2} \cdot y_s \cdot 10^{-3} \leq 4 \text{ Nm}$$

M_s = static moment around the longitudinal axis (x) [Nm]

m_n = load capacity [kg]

y_s = distance of center of gravity m_n to longitudinal axis (x) [mm]

Fig. 2.2-4

* only applies to reduced speed due to transfer gate and curve

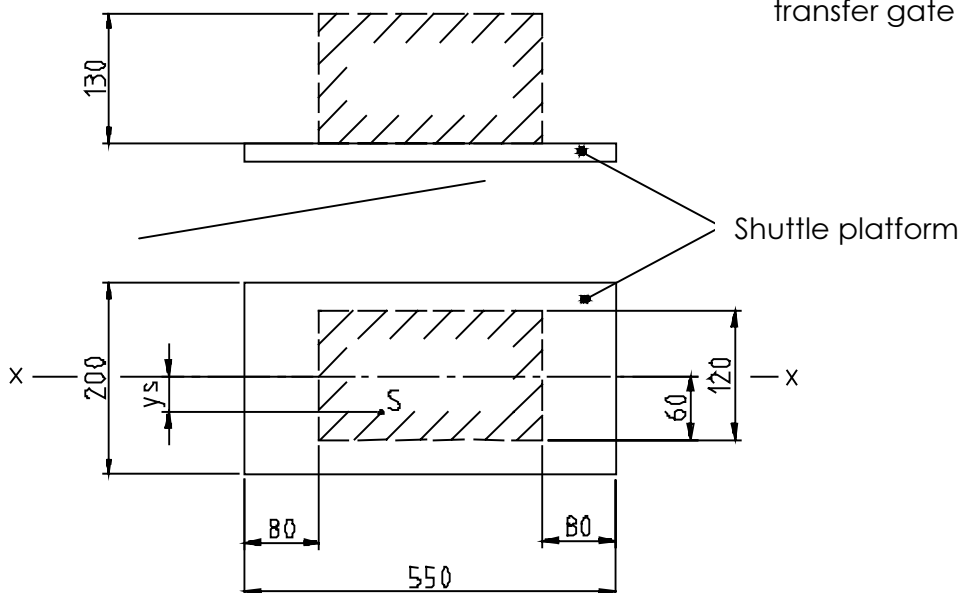

2.2.04.4 Safe Forces and Moments on the Shuttle Platform

(if it is locked in the positioning device)

Fig. 2.2-5

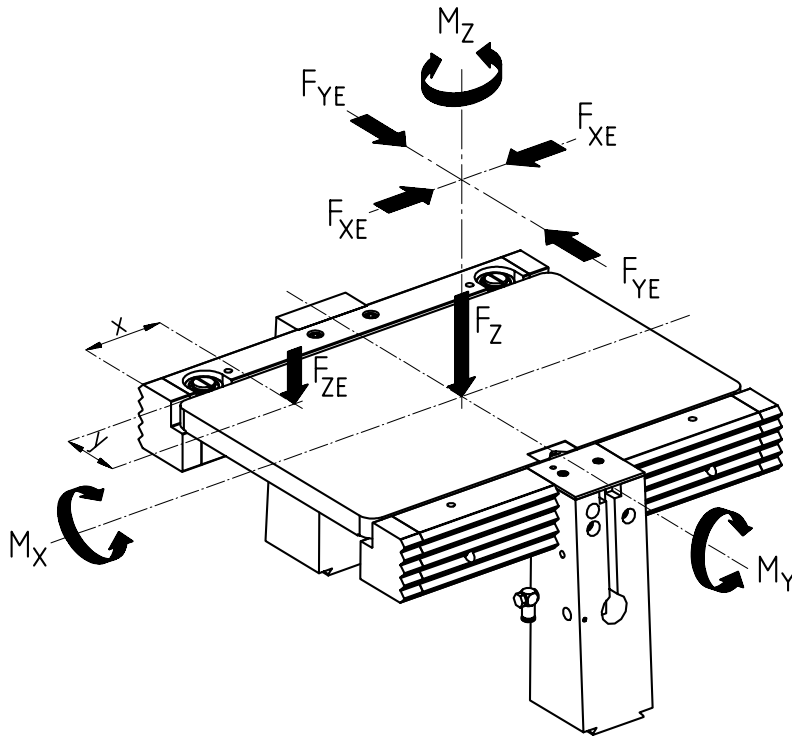

Nominal pressure 5 bar			Platform dimensions	
			200 x 550 mm aluminum	
$M_{X_{safe}}$	Single positioning	Nm	5	
$M_{Y_{safe}}$	Single positioning	Nm	7.5	
$M_{Z_{safe}}$	Single positioning	Nm	5	
$F_{X_{E_{safe}}}$	Single positioning	N	120	
$-F_{X_{E_{safe}}}$	Single positioning	N	120	
$F_{Y_{E_{safe}}}$	Single positioning	N	300	
$-F_{Y_{E_{safe}}}$	Single positioning	N	120	
$F_{Z_{safe}}$	Single positioning	N	3000	
$F_{Z_{E_{safe}}}$	Single positioning	N	500	

$x_{min} = 55 \text{ mm} / y_{min} = 25 \text{ mm}$

The values indicated affect a displacement of the shuttle platforms of a maximum of 0.3 mm in the direction of the force vector.

2.2.05 Hazards

2.2.05.1 Environment

Operating shuttles in an explosive atmosphere (flammable gases, vapors, or dust) can result in their combustion and shall be avoided.

2.2.05.2 Location of the Center of Gravity

The instructions regarding the distance of the "Center of Gravity of the Load to the Platform Surface" shall be absolutely followed (see "Load Limits" Fig. 2.2-4).

2.2.05.3 Risk of Squeezing on Manual Workstations with Positioning Device

When the shuttles are moved into positioning devices not protected by protection devices (e.g. manual workstations), it is absolutely necessary to reduce the shuttle speed.

To do this, the A-B cam is placed 150 mm before the entry edge of the positioning device beam (see Fig. 2.2-6).

Fig. 2.2-6

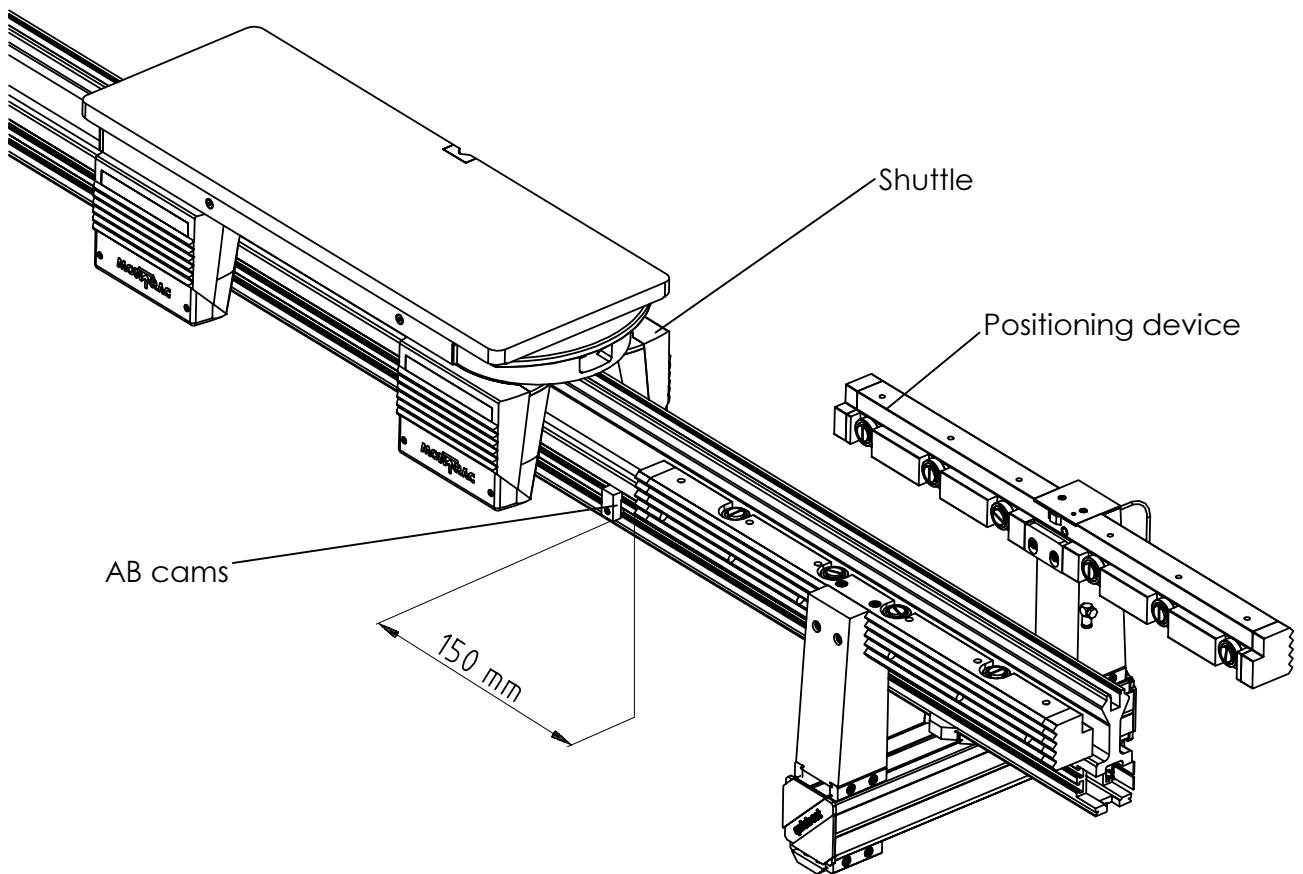

2.2.06 Installation

Fig. 2.2-7

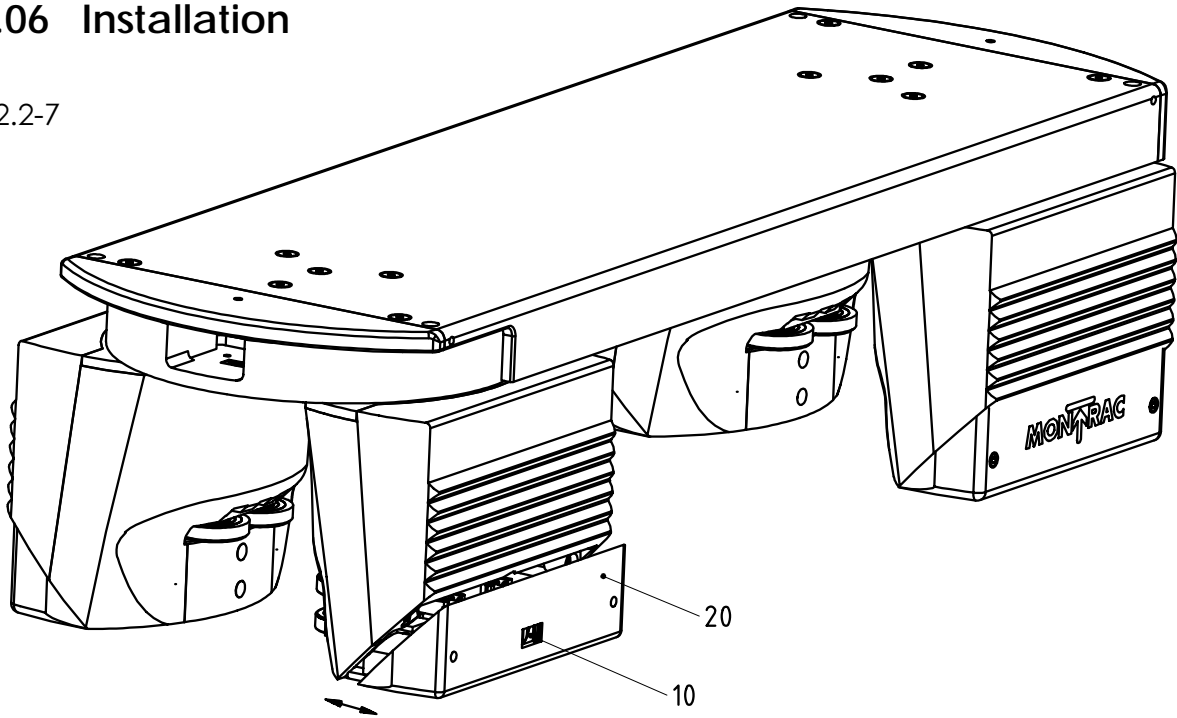

1. On shuttles that run clockwise, set the flip switch in the direction of movement (= shuttle is switched off).
2. On shuttles that run counterclockwise, set the flip switch against the direction of movement (= shuttle is switched off).
3. Prior to placing the shuttles on the track, check whether the current collectors (20, Fig. 2.2-7) are extended. If that is not the case, press on the release buttons (10, Fig. 2.2-7). The current collectors extend automatically.
4. The shuttle can now be placed on the track.
5. Push in the current collectors (20, Fig. 2.2-7) until the release buttons (10, Fig. 2.2-7) latch.
6. The shuttle is now ready for operation and can be started by flipping the switch. In this case, the LED gives a steady green light.

2.2.07 Disassembly

1. Stop the shuttle by placing an obstacle on the track (distance sensor).
2. Press the pushbutton (LED must be blinking green).
3. Extend the current collector as described in chapter "Installation" point 3.
4. Remove the shuttle platform.
5. Remove shuttle from the track.

2.2.08 Troubleshooting

Problem	Cause	Elimination
Shuttle does not run. LED is not illuminated.	Power interruption.	Check the supply voltage (24 V).
	Wire breakage in the current collector.	Replace current collector as described in chapter 2.2.09.4.
	Heavy contamination between contact springs (30, Fig. 2.2-14) and carbon rollers (20, Fig. 2.2-14).	Replace current collector subassembly (item no. 91166) as described in chapter 2.2.09.4.
Shuttle does not run. LED is red (= overload of the drive for approx. 15-30 sec.)	Mechanical locking of the shuttle by positioning devices (PV) or stop (at the stop/start element).	Check the control sequence. Check the pneumatic drive elements of the PV and the stop device. Turn the flip switch off and on again.
	Cause is not apparent.	Cannot be eliminated. Replace the "Front Axle" as described.
Shuttle does not run. LED is green.	Distance sensor senses an obstacle.	Remove the obstacle.
	Distance sensor is defective.	Replace the distance sensor as described.
	B-sensor is misadjusted.	Adjust B-sensor as described.
Shuttle does not run. LED is blinking red.	A and/or B sensor is defective.	Replace sensor as described.
	PLC is defective.	Replace PLC as described.
	Cause is not apparent.	Cannot be eliminated. Replace the "Front Axle" as described.
Shuttle does not run. LED is blinking green.	The shuttle has power but is not switched on.	Press the pushbutton switch.
Shuttle does not run. LED is blinking orange.	Voltage drop (<19V).	If the voltage drop is systematic, it must be eliminated.
Shuttle is running at V_{red} (12 m/min.)	Result of a power interruption.	If the power interruption is systematic, it must be eliminated.

2.2.09 Problem Elimination

2.2.09.1 Replacing the "Front Axle" (10, Fig. 2.2-11)

1. Press the ON/OFF pushbutton.
2. Remove the shuttle platform from the shuttle.
3. Replace current collector as described in chapter "2.2.07 Disassembly."
4. Lift shuttle from the track.
5. Remove the 3 flat-head screws (item 10, Fig. 2.2-8).
6. Attach the new "Front Axle" (10, Fig. 2.2-11) with flat-head screws to the profiled section of the bogie (20, Fig. 2.2-11).
7. Place the shuttle on the track.
8. Assemble the current collector as described in chapter "Installation."
9. Replace the shuttle platform.
10. Press the ON/OFF pushbutton.

2.2.09.2 Replacing the Distance Sensor (50, Fig. 2.2-8)

1. Disassemble the "Front Axle" as described before (steps 1-5).
2. Loosen the screws (30).
3. Remove the distance sensor (50) by lifting it up.
4. Pull the cable (40) out of the distance sensor.
5. Place the cable on the new distance sensor (50) and insert it in the housing opening so that the two position cams fit in the two holes. Guide the flat cable between the distance sensor and the cylinder pin.
6. Tighten screws (30) on a polyamide washer.
7. Mount the "Front Axle" as described before.
8. Install the shuttles as described in chapter "Installation."

Fig. 2.2-8

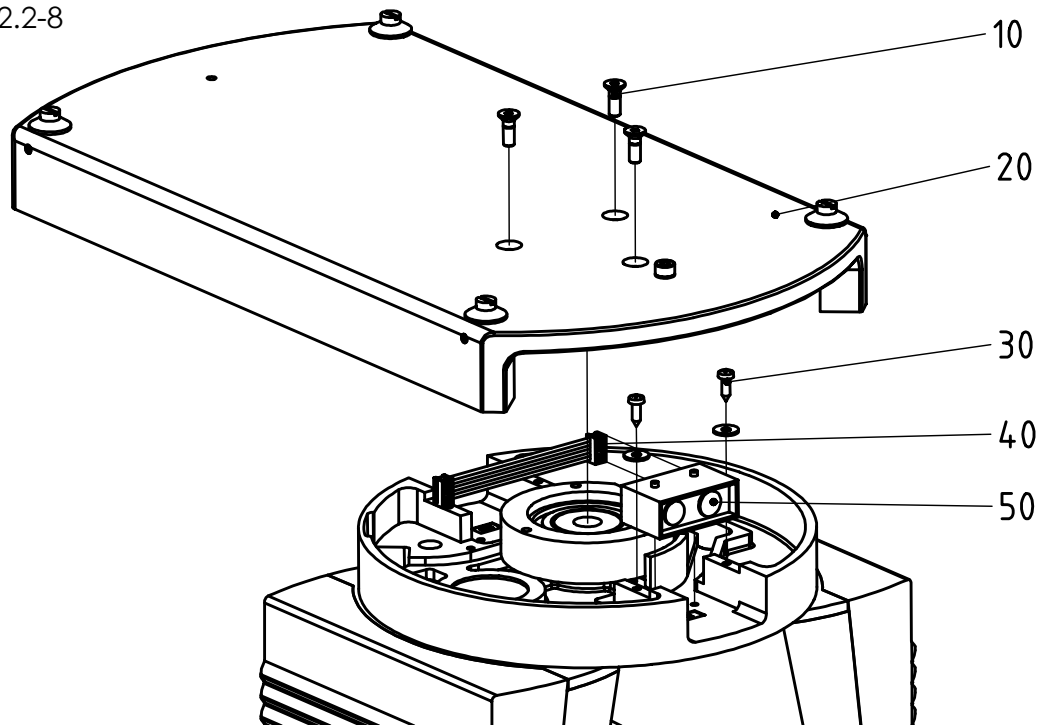

2.2.09.3 Replacing the PLC (Fig. 2.2-9)

1. Remove the shuttle from the track as described in chapter "Disassembly."
2. Remove the 3 screw (10, Fig. 2.2-8). Caution! Prior to the next step, the person performing this work needs to be properly grounded! The PLC contains components sensitive to touch.
3. Loosen the screws (60, Fig. 2.2-12).
4. Remove cover (10, Fig. 2.2-12).
5. Loosen the screws of the PLC cover (50, Fig. 2.2-12).
6. Disconnect all bushings from the PCB connector.
7. Disconnect all five cables (Fig. 2.2-9) from the PCB connector.
8. Reassemble as described in points 6-2.
9. Install the shuttle as described in chapter "Installation" steps 1-6.

Fig. 2.2-9



2.2.09.4 Replacing the Current Collector (Fig. 2.2-10)

1. Remove the shuttle from the track as described in chapter "Disassembly."
2. Close the drawer (30, Fig. 2.2-10).
3. Loosen the two screws (10, Fig. 2.2-14).
4. Remove the clamp (10, Fig. 2.2-10) of the power supply cable.
5. Pull the cable ties (20, Fig. 2.2-10) out of the square holes.
6. Mount the new current collector as described in point 4-2.

Fig. 2.2-10

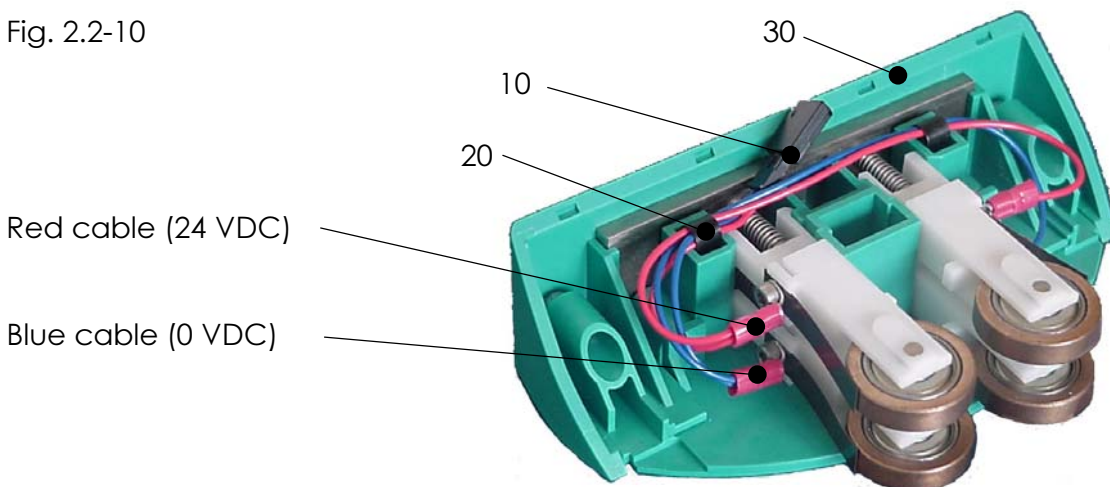

2.2.10 Maintenance

every 4 weeks

2.2.10.1 Cleaning the Lens

- Remove dust with a blower
- Remove grease with a degreasing cleaner

Caution, do not use aggressive solvents (acetone, etc.)!

2.2.10.2 Checking the Rear Cover

Check the rear cover for heavy contamination and mechanical damage. Clean heavily contaminated rear cover (with cleaning agent). If the rear cover is damaged, please contact MONTECH!

2.2.10.3 Checking the Track Rollers

Check if the track rollers make contact with the track. If that is not the case, this defect is usually due to overload. Please contact MONTECH!

2.2.10.4 Checking the Housing

Check the entire shuttle for outer damage (e.g., cracks or broken-off parts, ...)

2.2.10.5 Checking the Carrying Rollers

Check the rollers for excessive wear and damage (e.g., visible flattening or surface cracks).

2.2.10.6 Checking the Sensors

Check the proximity switches A and B for outer damage (e.g., mechanical wear of the sensor cap). If that is the case, please contact MONTECH!

2.2.10.7 Checking and Cleaning the Current Collectors

Blow any carbon debris out of the current collectors and check the following points:

- Do the carbon rollers turn?
- Can the carbon rollers make spring contact without obstacles?

If damage cannot be repaired immediately, the current collector shall be replaced.

2.2.10.8 Cleaning the Shuttle

Remove excessive dirt from the shuttles.

Caution, do not use aggressive solvents (acetone, etc.)!

2.2.11 Exploded Views

See the following pages.

2.2.11.1 Shuttle, Complete

Fig. 2.2-11

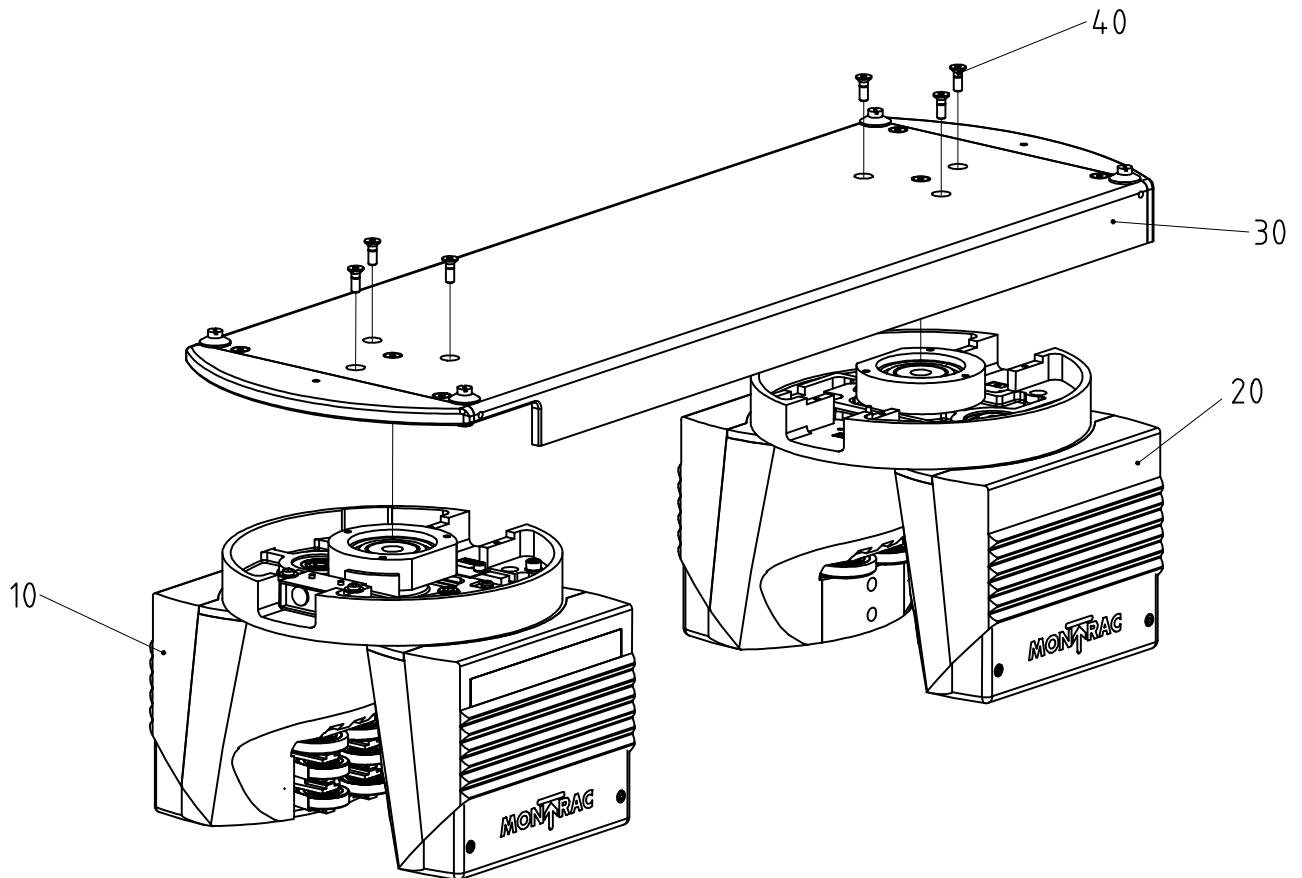

Two-axle shuttle (with empty rear axle), complete: item no. 91422 (cw), 91423 (ccw)

Item	Item No.	Name
10	90890	Axle, front, cw
10	90891	Axle, front, ccw
20	90994	Axle, rear
30	91523	Bogie 550 complete
40	504392	Flat-head screw M 4x 12 BN 616

2.2.11.2 Axle, Front

Fig. 2.2-12

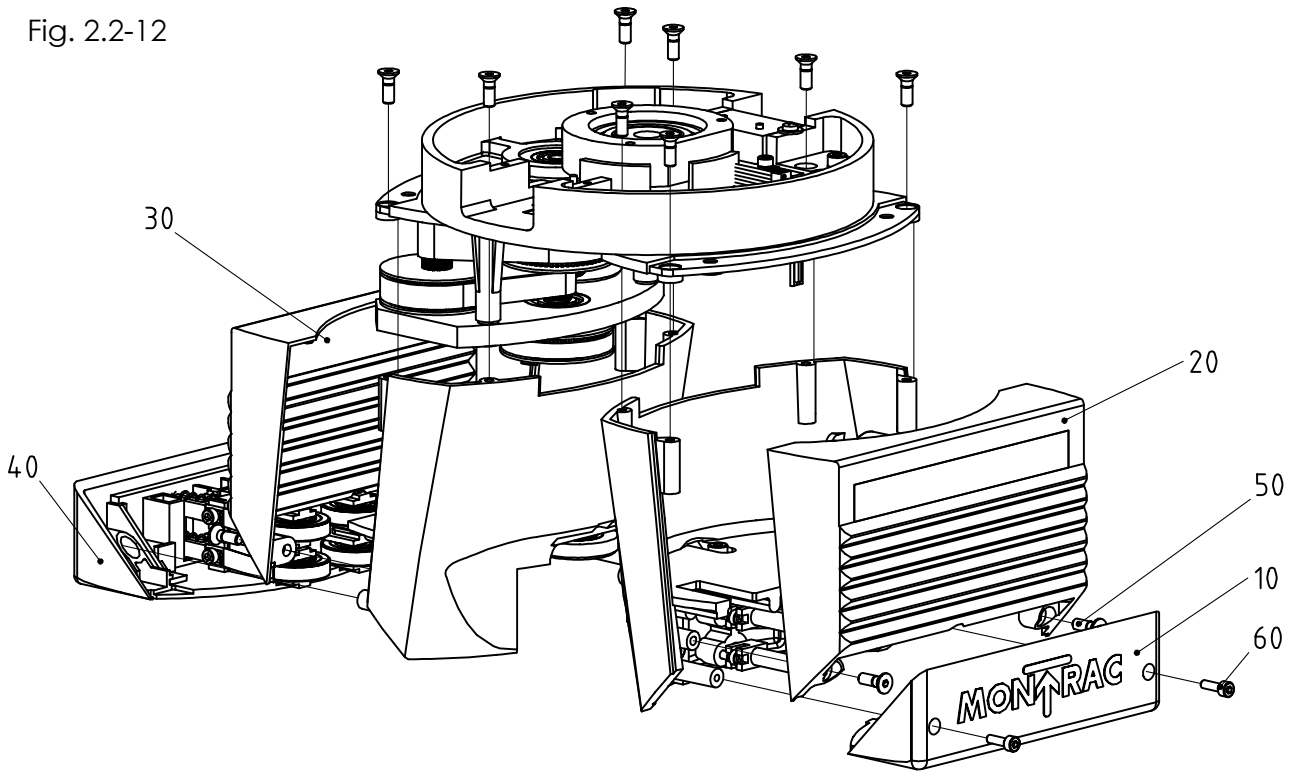

Axle, Front Item No. 90890 (cw)/ 90891 (ccw)

Item	Item No.	Name
10	91167	Cover, pre-assembled
20	90840	Motor control, MM3, pre-assembled
30	90887	Cover (transmission side)
40	91166	Current collector to shuttle
50	501799	Flat-head screw M 4 x 12
60	505270	Cylindrical screws M 3 x 8

2.2.11.3 Axle, Rear

Fig. 2.2-13

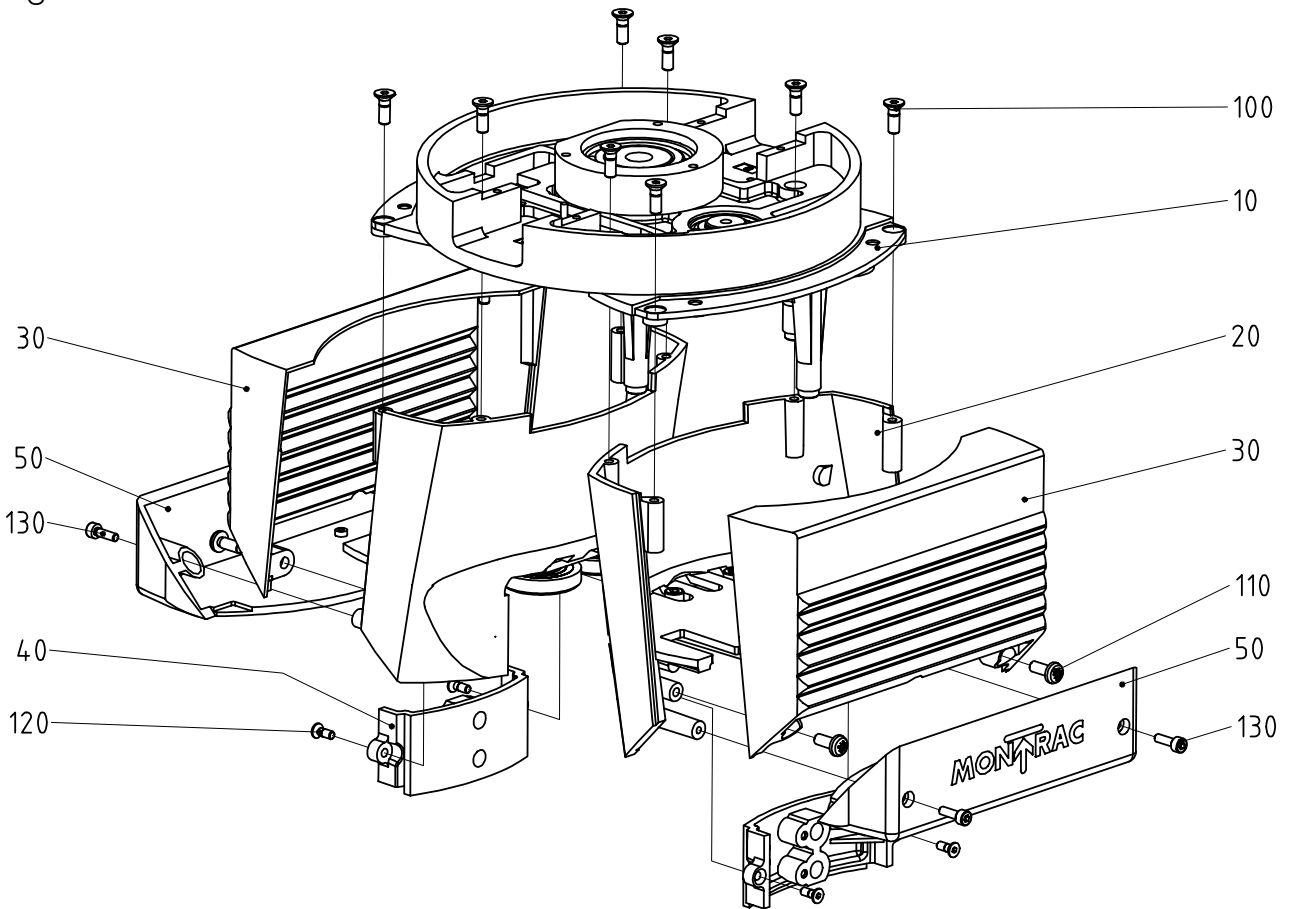
**Axle, Rear, Item No. 90994 (cw + ccw)**

Item	Item No.	Name
10	90995	Carrier platform, pre-assembled (rear axle empty)
20	91298	Housing, pre-assembled (shuttle 3)
30	90887	Cover (to transmission side)
40	90866	Proximity switch holder
50	90812	Cover
100	506845	Flat-head screw M 4x 12
110	505493	Cylindrical screw M 4x 10
120	506739	Flat-head screw M 3x 8
130	505270	Cylindrical screw M 3x 8

2.2.11.4 Current Collector, Item No. 91166

Fig. 2.2-14

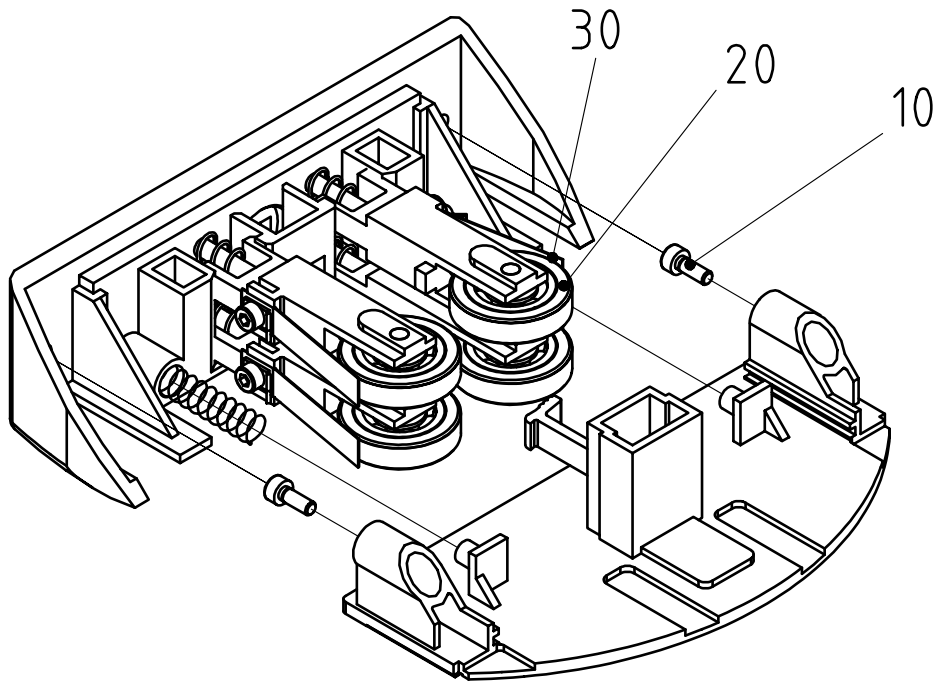

2.2.12 Environmental Friendliness and Disposal

2.2.12.1 Materials Used

- Aluminum
- Copper
- Bronze
- Stainless steel
- Metal bearing carbon
- Electronic components
- Polyvinyl chloride (PVC)
- PMMA
- Butadiene acrylonitrile rubber (NBR)
- Polyurethane (PUR)
- Polycarbonate (ABS blend)
- Polychloroprene
- Polyethylene (PE)
- Polyoxymethylene (polyacetal) (POM)
- Paper

2.2.12.2 Surface Treatment

- Anodizing of aluminum
- Galvanizing of steel
- Electrical nickel-plating of steel
- Electrical silver-plating of bronze
- Blackening of steel

2.2.12.3 Forming Processes

- Aluminum extrusion
- Aluminum diecasting
- Non-cutting machining of aluminum, steel, POM, PUR
- Compression/injection molding of NBR, ABS, PUR, PMMA, PE, polychloroprene
- Stamping of steel, bronze, and PVC

2.2.12.4 Emission during Operation

- See EMC emissions
- Complies with clean room category 1000 (under defined conditions)

2.2.12.5 Disposal

Shuttles that can no longer be used should not be recycled as entire units, but disassembled and then recycled according to the material types used. The material type of each component is listed in the spare parts lists. Material that cannot be recycled must be disposed of in the appropriate manner.