



OPERATING INSTRUCTIONS

Power unit KTB 24 V / 4.3 A

Issue:

507513 A

Manufacturer:

Montech AG, Gewerbestrasse 12, CH-4552 Derendingen

Tel. +41 (0)32 681 55 00, Fax +41 (0) 682 19 77

Technical data:

Input voltage range	85-264 VAC (50/60 Hz), 120-370 VDC
Input current	1.4 A (100 V), 0.7 A (200 V).
Efficiency	81 % (100 V), 84 % (200 V)
Power factor	0.99 (100 V), 0.94 (200 V)
Switch-on current rush	15 A (100 V), 30 A (200 V)
Output voltage	24 VDC
Output current	4.3 A
Protection category	IP 54
Ambient temperature	10° to 40° C
Relative humidity	20 – 90 %, no condensation
EMC compatibility:	Standards EN 50081-2, EN 61000-6-2
Switch	On/off, primary side with light emitting diode
Conformity	CE
Weight	1.6 kg

Connection and commissioning

Input side:

- Cable 3x0.75 mm², length 3 m
- 3-pin plug, Swiss version or safety plug supplied
- Live (L), brown
- Neutral (N), blue
- Earth (PE), yellow/green

Output side:

Possible connection:

- 1) One mini conveyor version S or L
- 2) Two mini conveyors version L*
- 3) One mini conveyor version S or L plus control line

* Two mini conveyors version S if the total current consumption is <2.5 A (continuous current) and there is no start/stop operation.

Mini conveyor connection

- Disconnect power unit from the mains
- Remove cover (1) and seal (2) by unscrewing the four screws (3)
- Pull out retaining plate with circuit board (4) slightly

Connection and commissioning

- Pull out plug (5)
- Draw connecting cable for mini conveyor through cable screw union (6) and mount end sleeves. Max. conductor cross-section: 1.5 mm²
- Cable length from lock nut of cable screw union (7) to plug (5): 35 mm.
- In the case of additional cable for control or second conveyor, replace cover (8) by cable screw union supplied. Mount end sleeves on cable.
- Connect connecting cable of mini conveyor and any control line to plug (5) according to the diagram in Fig. 2.
- Insert plug into base housing (9) and secure screws.
- Mount cover (1) with seal (2) and screw in screws (3).
- Fastening to chassis of mini conveyor
- With the aid of the supplied lock nuts (9), mount countersunk washers and countersunk screws in T-slots of the conveyor chassis.
- Switching on the power unit
- Connect to mains with voltage in the range 85-264 VAC (50/60Hz) or 120-370 VDC
- Switch on the power unit at switch (11)

Fig. 1, Assignment of connecting cable of mini conveyor

(Cable included in the delivery of the mini conveyor)

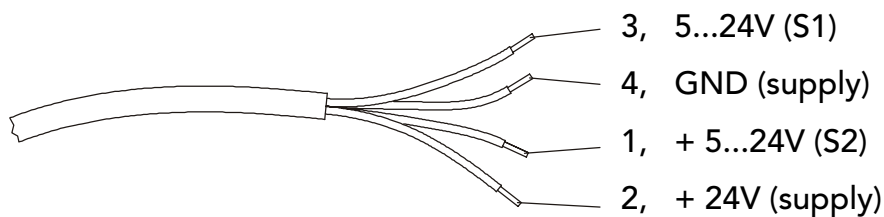

Figures

Fig. 2, Circuit diagram

Connection: Mini conveyor and PLC control

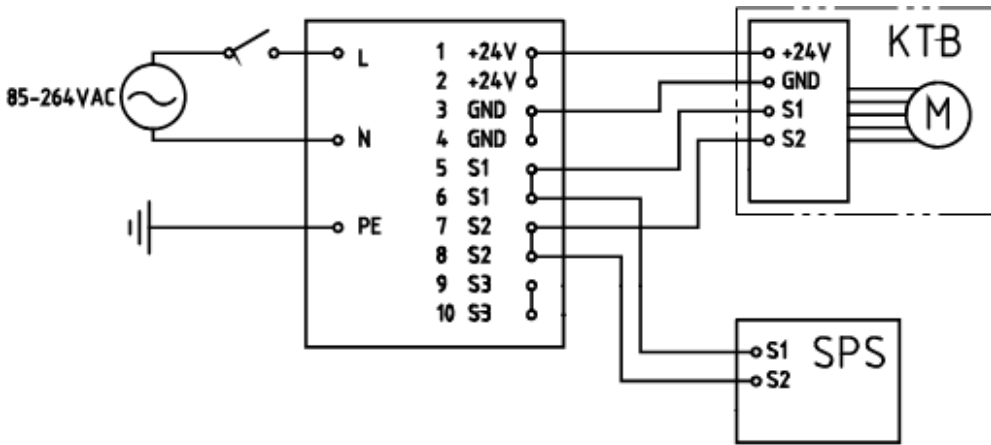

Connection: Two mini conveyors

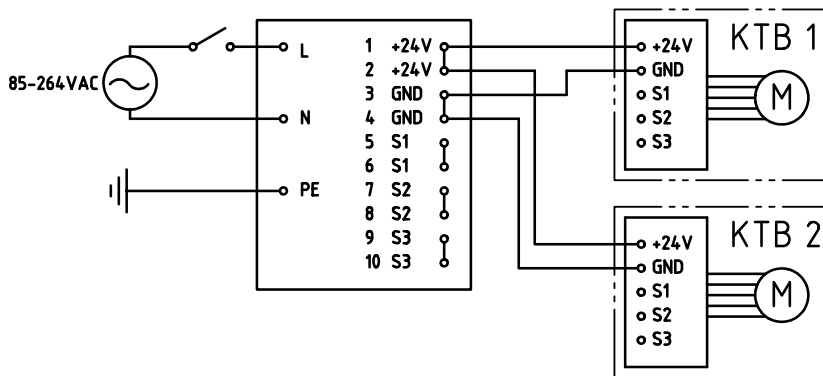
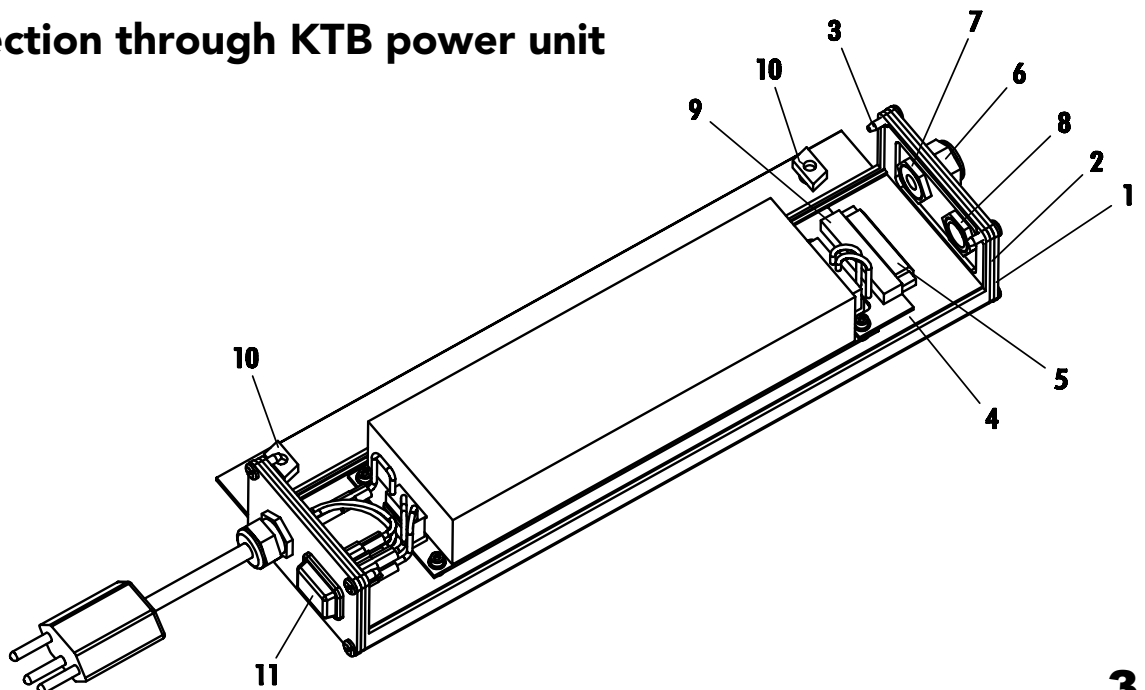

Fig. 3, Section through KTB power unit



Safety instructions

Safety instructions:

The following safety instructions must be followed in all phases of commissioning, operation and service or repair work. Failure to follow these instructions constitutes misuse of the unit.

Earthing the unit:

The unit must be earthed in order to achieve optimal protection in the event of contact.

CAUTION!

In order to avoid the risk of a fire in the event of partial overheating, the unit may not be operated in a dusty atmosphere.

The unit may not be operated in a humid atmosphere or exposed to rain or dew since this may produce an electrical connection between the mains and the control inputs.

The operator of this unit must have connection, commissioning, adjustment and service performed by qualified personnel. Work on the electrical parts of this unit is particularly dangerous since the unit operates with electrical voltages which can lead to death and these voltages may also be present after the supplied network has been switched off. It is therefore absolutely essential to switch off the mains and to wait for discharge of the capacitors present in the unit before beginning any service work.

Avoid any contact with the circuits of the unit. During operation, any contact may be life-threatening. Moreover, the unit may be damaged by static discharge if the circuits are touched.

In order to avoid additional risks, do not make any modifications or obtain the manufacturer's consent before any modification, replacement of components or installation of additions.