



Handling Components

# **OPERATING INSTRUCTIONS**

Rotary Units:      DAP-3

Issue:                BA-100024

## **Important information**

EU Certificate of Conformity (CE) .....	1
Scope of the instructions .....	2
Technical data .....	3
Performance diagram .....	4
Pressure-torque diagram .....	5

## **Commissioning**

Mounting position .....	6
Mounting .....	7
Mounting moving bodies on the axis of rotation .....	8
Passage of cables and hoses .....	10
Input of compressed air .....	10
Adjusting the angle of rotation .....	11
Adjusting the shock-absorbers .....	12
Adjusting and connecting the inductive proximity switches .....	12
Technical data of MONTECH standard components .....	14
Formulas for calculating moments of inertia .....	16

## **Maintenance**

Inspecting the shock-absorbers .....	17
Lubrication .....	17

## **Spare parts lists**

DAP-3 .....	18
Suppliers and list of materials .....	20

## **General notes**

Environmental compatibility and disposal .....	22
--	----

## **EU Certificate of conformity** (as per MRL Appendix II A)

Regulations and standards taken into account:

- Guidelines for machines 89/392/ECC, 91/368/ECC

### **Manufacturer**

Montech AG

Tel. 032 / 681 55 00

Gewerbestrasse 12

Fax. 032 / 682 19 77

CH-4552 Derendingen

### **Description of product and use**

Rotary drives DAP-3 are used where ever regularly rotating movements forwards and backwards have to be performed.

Under all circumstances the performance limits quoted in the technical data have to be taken into account.

With freely rotating masses particular attention must be paid to the mass moment of inertia.

### **Risks**

The actuation of freely rotating masses with rotary drives DAP-3 is only permissible when it is safeguarded by MOVING, ISOLATING PROTECTIVE DEVICES in accordance with EN 292-2, para 4.2.2.3.

The cover (Fig. 20; item 130) may only be removed to carry out adjustments and lubrication (danger of contusion injury). In automatic operation never work without the cover fitted.

### Additional information

The aim of the present User Manual is to enable users to employ the rotary drive DAP-3 correctly and safely. Should further information be required in relation to your particular application, please contact the manufacturer. When reordering User Manuals, it is essential to quote the reference number, the product name and serial number.

This document can be obtained from our homepage [www.montech.com](http://www.montech.com).

Fig. 1-1: Description of type plate

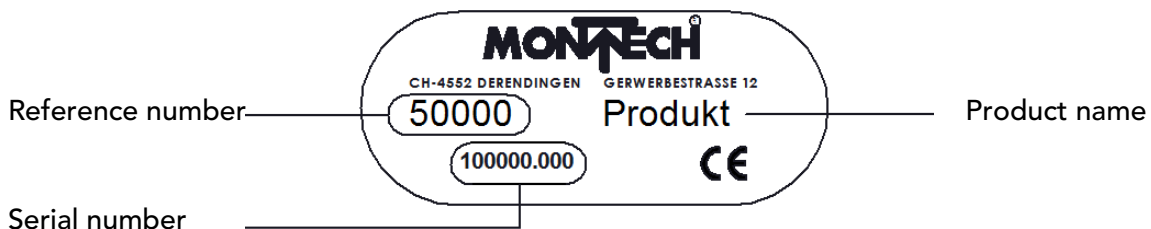

Montech AG  
Management

U. D. Wagner

C. Wullschleger

### Validity of the User Manual

Our products are continually updated to reflect the latest state of the art and practical experience. In line with product developments, our User Manuals are continually updated.

Every User Manual has an order number (e.g. BA-100024) and an edition number (e.g. 02/2006). The order number and the addition number are shown on the title page.

## Technical Data

		<b>DAP-3</b>
Range of adjustment of angle of rotation	(°)	60 ... 180
Torque at 5 bar	(Nm)	see pressure-torque diagram
Permissible moment of inertia	(kgcm <sup>2</sup> )	30'000
Piston diameter	(mm)	60
Rotation time	(s)	see performance diagram
Repeatability	1) (°)	≤ 0.02
Permissible shaft loading	2) (Nm)	100
Permissible axial load tension/compression	(N)	3'000/5'000
Weight	(kg)	11
Operating pressure	(bar)	2 ... 6
Ambient temperature	(°C)	10 ... 50
Operating medium		oiled or unoled air, filtered to 5 µm
Damping in end positions		hydraulic shock-absorbers
Check of end positions	3)	induct. proximity switch
Compressed air input		hose 4 ID/6 mm O.D. dia. to push-on union
Speed regulation		adjustable exhaust throttles with R 1/8" thread and push-on union 6 mm dia.
Service life		> 10 <sup>7</sup> double strokes
Ref. No.		<b>45055</b>

1) Variation of end positions during 100 successive strokes

2) Load acting about the longitudinal axis of the rotating shaft

3) See special accessories

### Special accessories

Inductive proximity switch PNP, M8x1 with LED, proof against short circuit and wrong polarity, with a switching clearance of 2 mm, plug-in Ref.No. 505 118.

# Performance diagram \*

Fig. 3

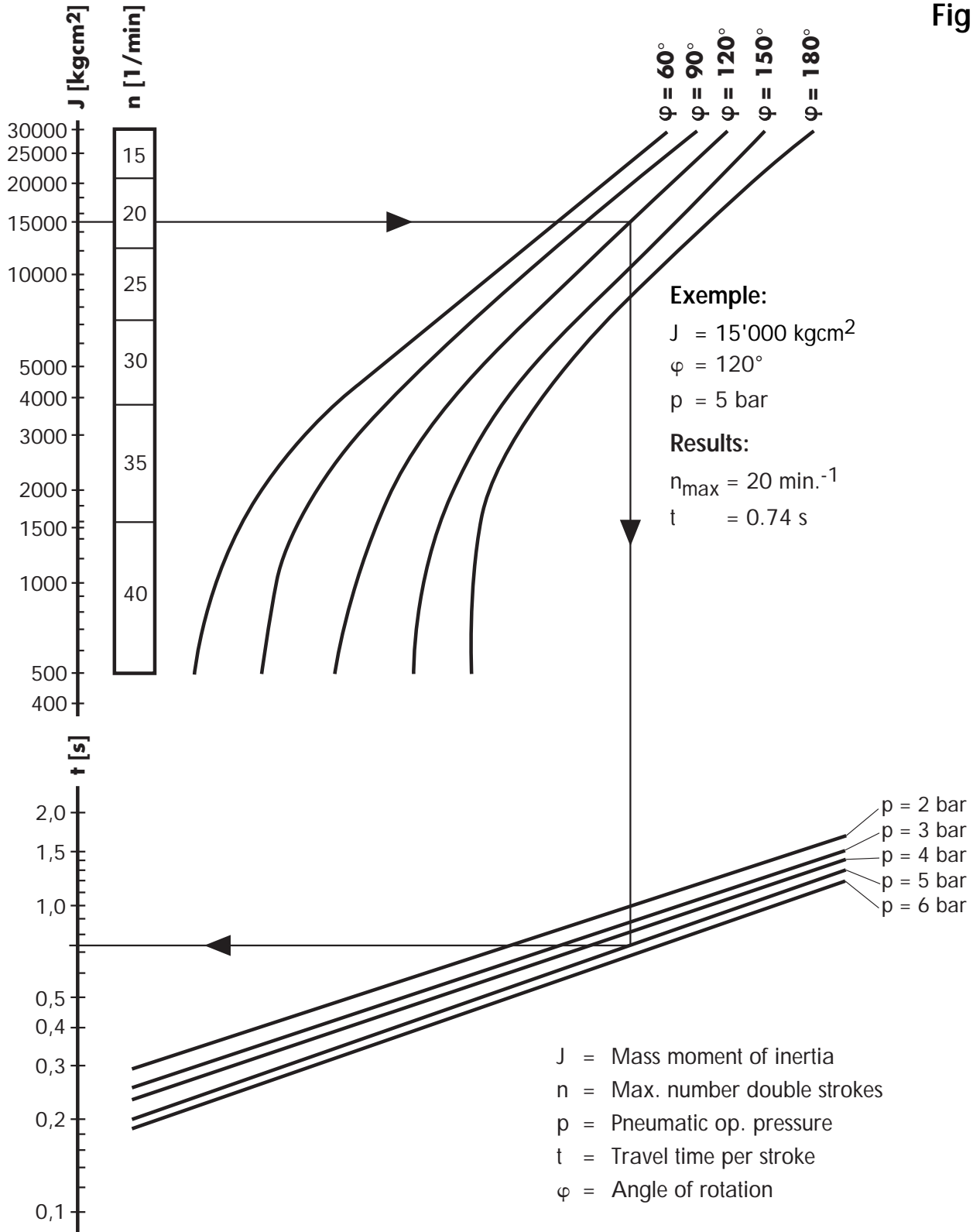

\* Scope: – Centre of gravity of the rotating mass located on the axis of rotation, which may be in any position.  
 – Centre of gravity of the rotating mass off set from the axis of rotation, with the axis vertical.

## Pressure-torque diagram

Fig. 4

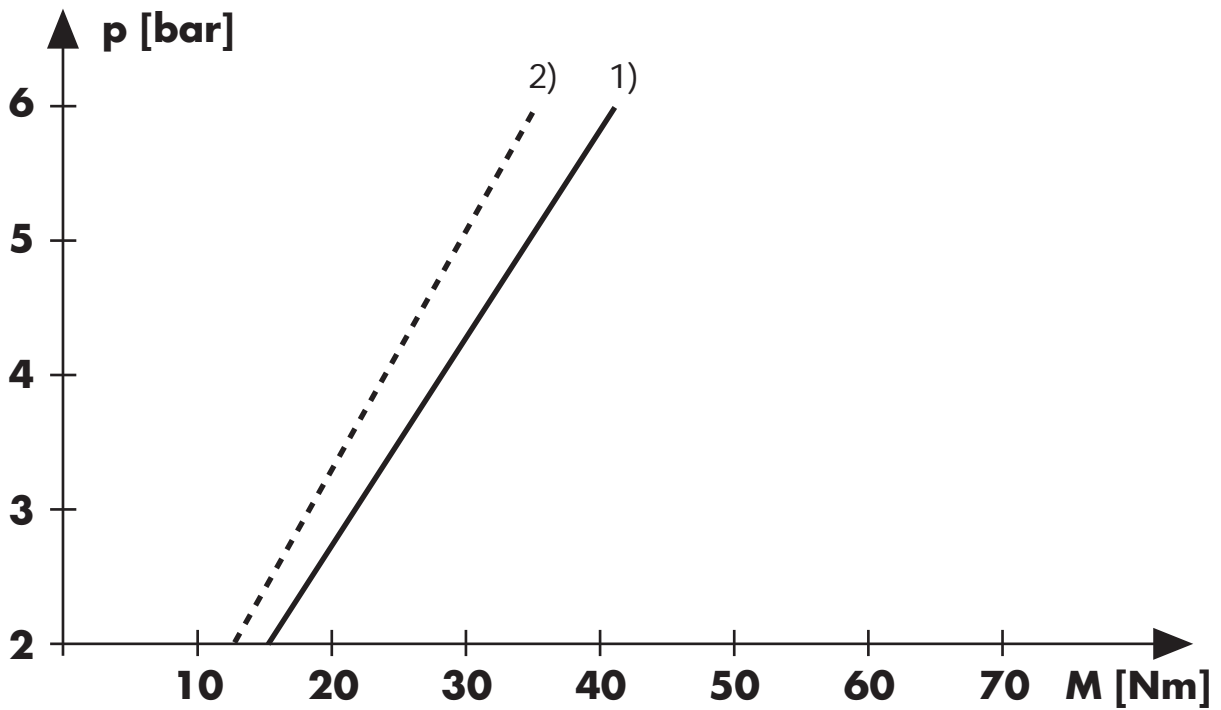

$p$  = Pneumatic operating pressure

$M_H$  = Holding torque; corresponds to that which can be externally applied to the stationary pinion shaft, without it moving.

$M_B$  = Moving torque; corresponds to that made available by the pneumatic drive at the rotating pinion shaft.

### DAP left-hand/right-hand end position

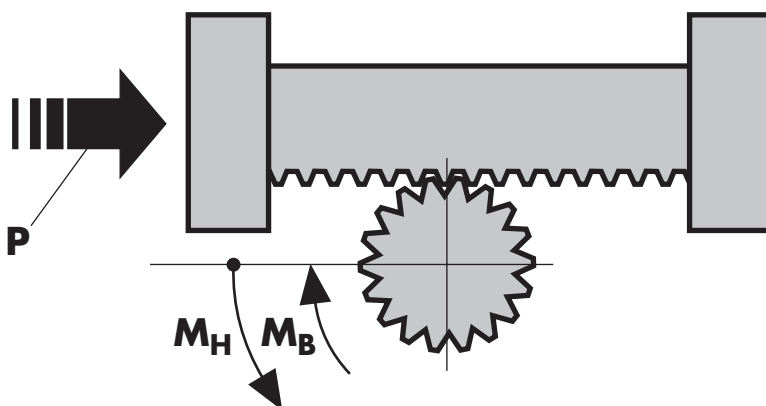

$$M_H = p * 6.917 \quad 1)$$

$$M_B = p * 6.0 \quad 2)$$

## Mounting position

In principle, the rotary units may be mounted in any position. But it should be borne in mind that when the axis of rotation is not vertical and the centre of gravity of the mass is eccentric with respect to the axis of rotation, additional variable torques are likely to occur. They may be either in the direction of rotation or in the opposite direction. The result is that the permissible mass moment of inertia has to be reduced from 30'000 kgcm<sup>2</sup> and that the time (t) shown in the performance diagram (Fig.3) becomes longer owing to the speed being reduced.

Fig. 5

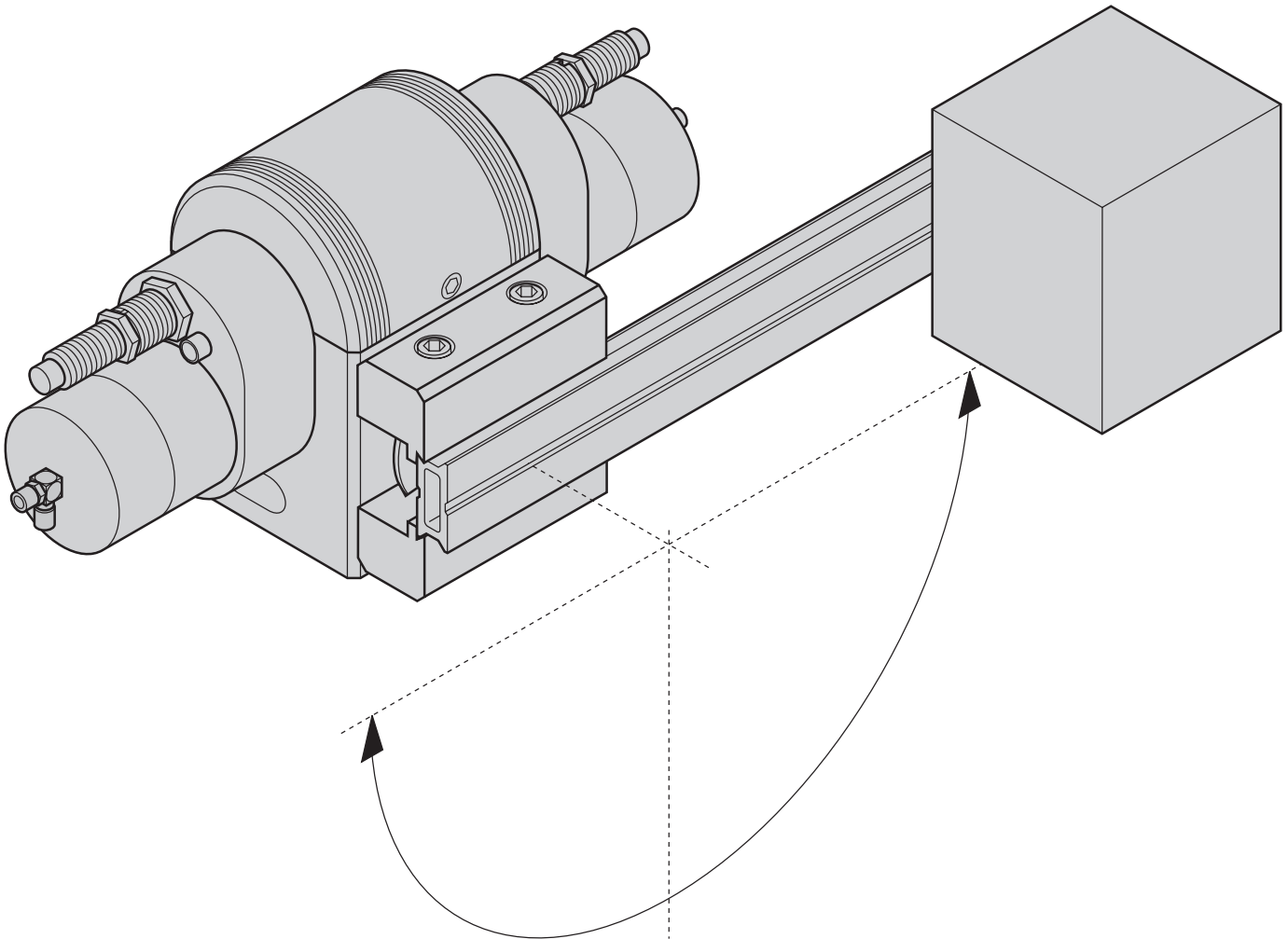

## Mounting

The rotary unit DAP-3 is mounted either by means of four M8 fixing holes on two sides of the housing, or with an adaptor plate (Ref.No. 45338) to any available QUICK-SET dovetail.

With the MONTECH Quick-Set components mounting structures can be constructed quickly and easily.

Any correction to the position of the rotary unit (displacement of the axis) determines which of the four methods of mounting is most suitable.

Fig. 6

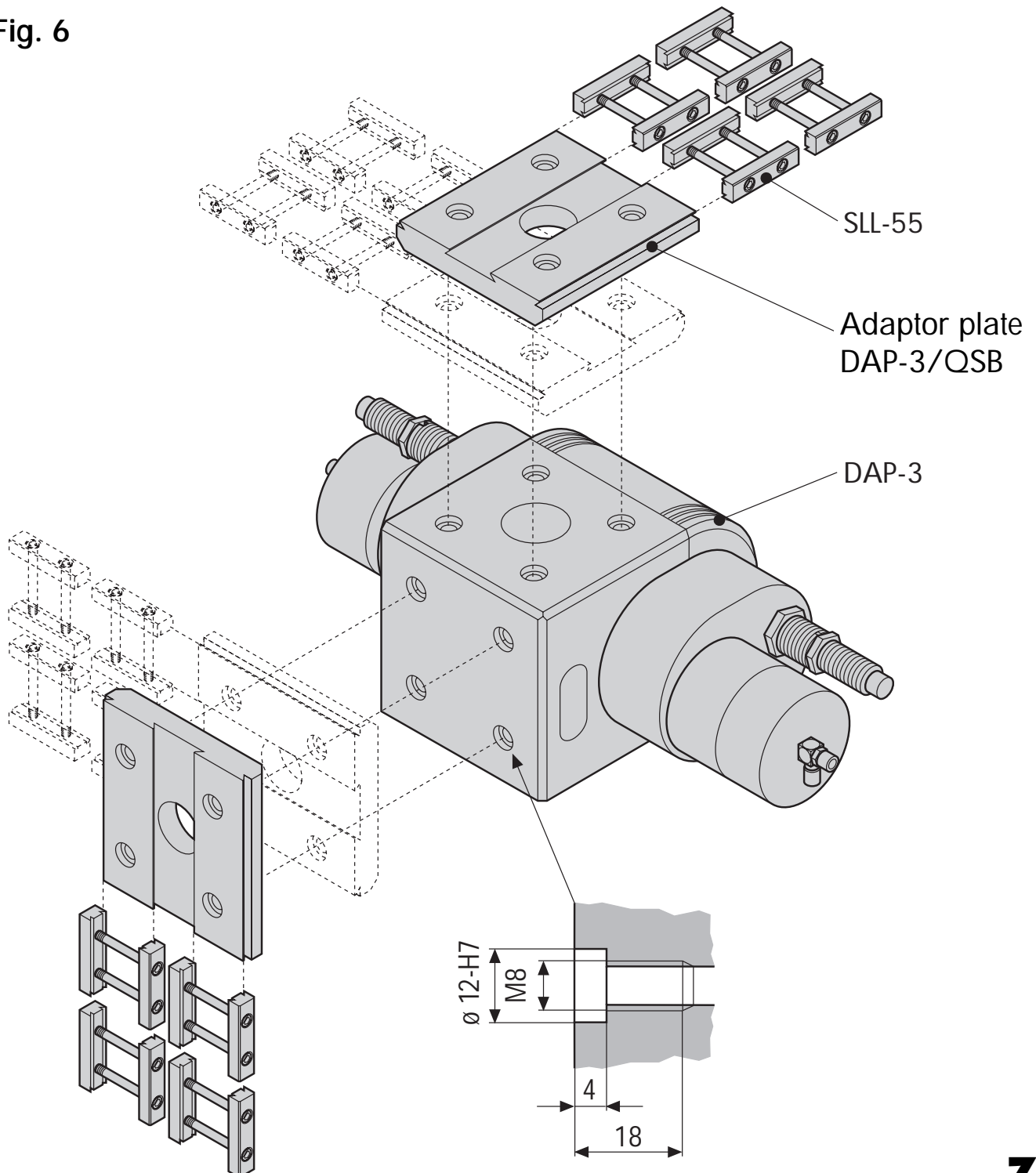

## Mounting moving bodies on the rotating axis

Mounting with QUICK-SET-supporting profiles

Fig. 7

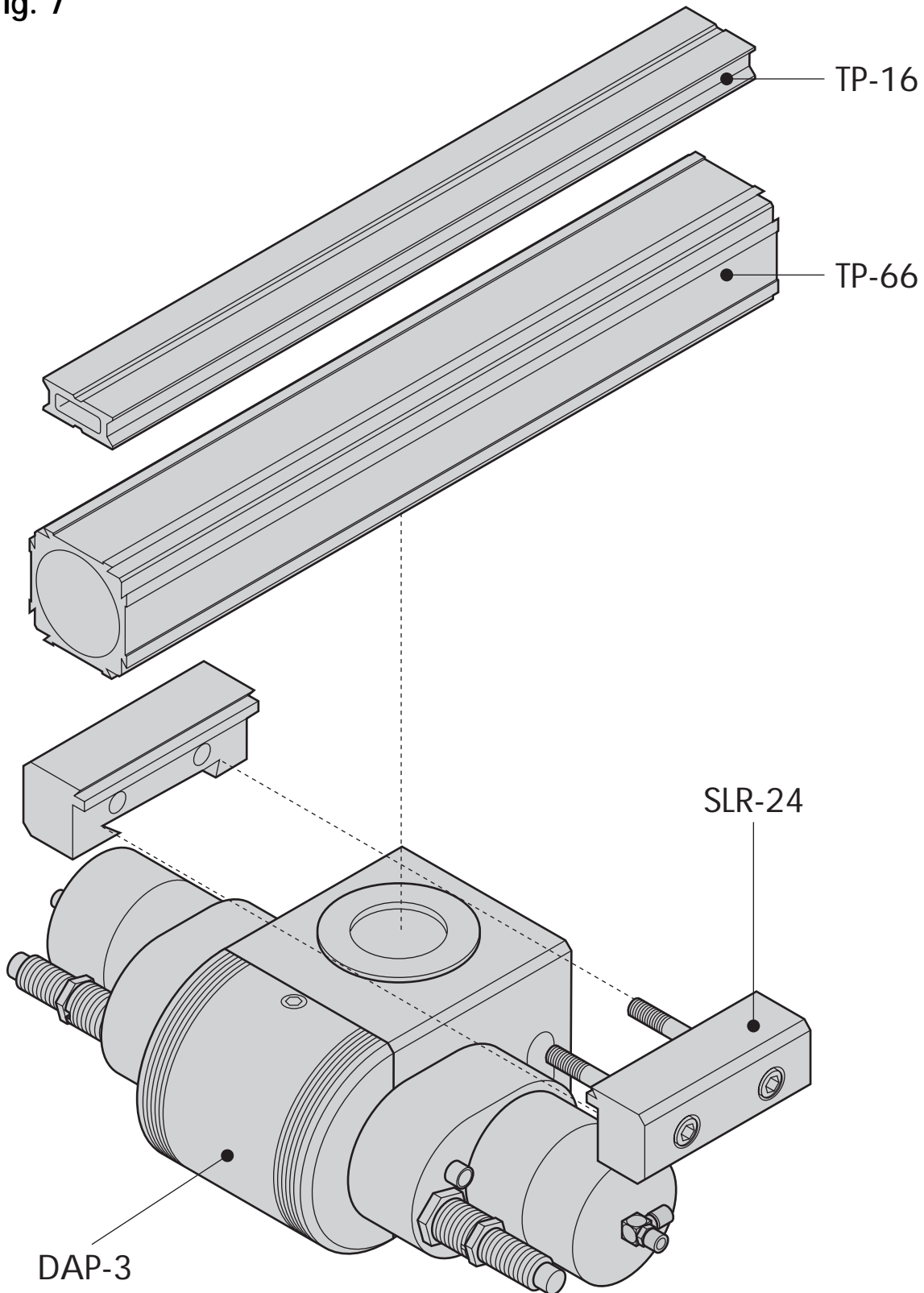

Linear unit attached by SRL 24

Fig. 8

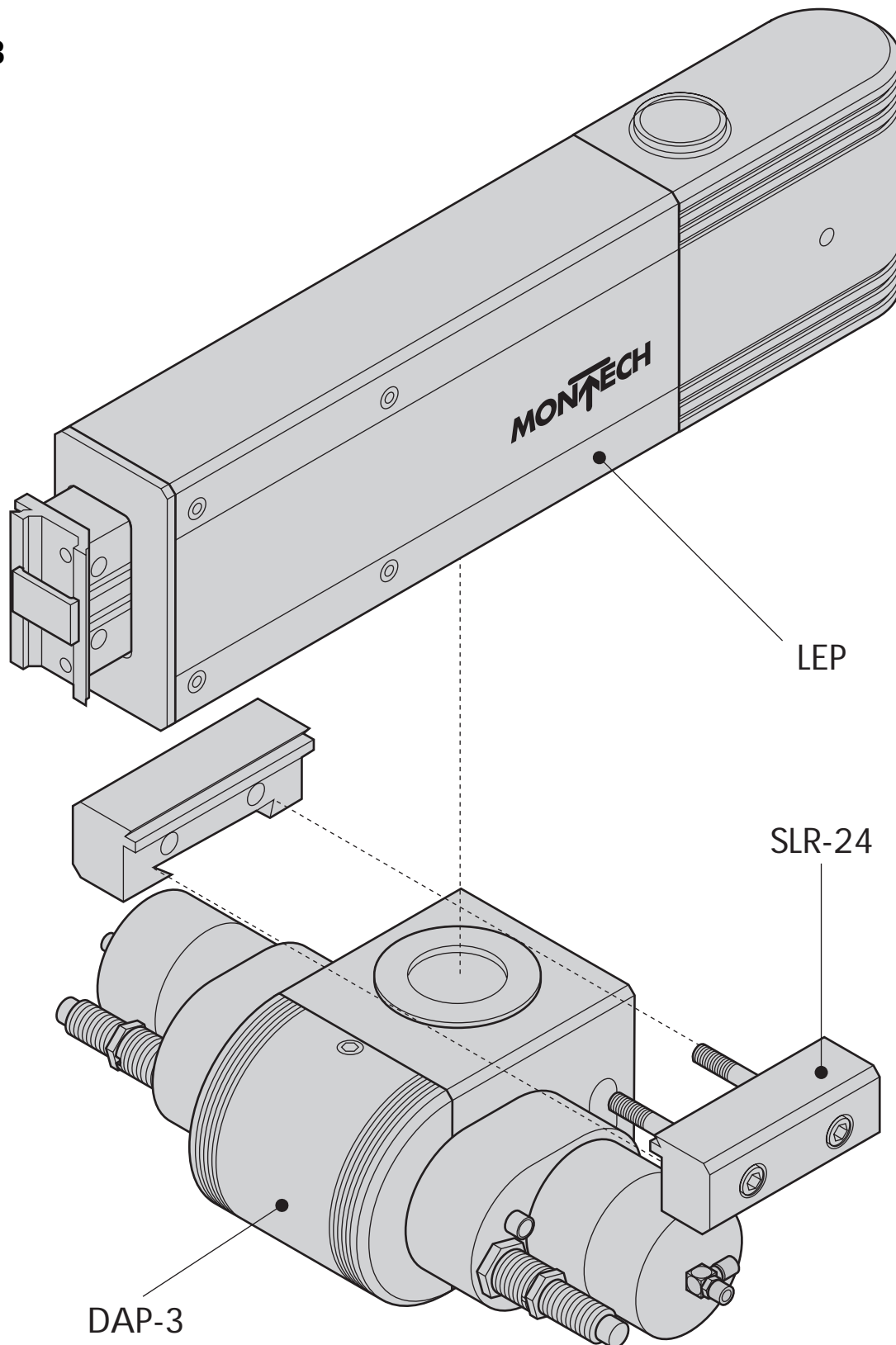

## Passage of cables and hoses

Pneumatic hoses and external cables can be passed through the hole in the pinion shaft.

Fig. 9

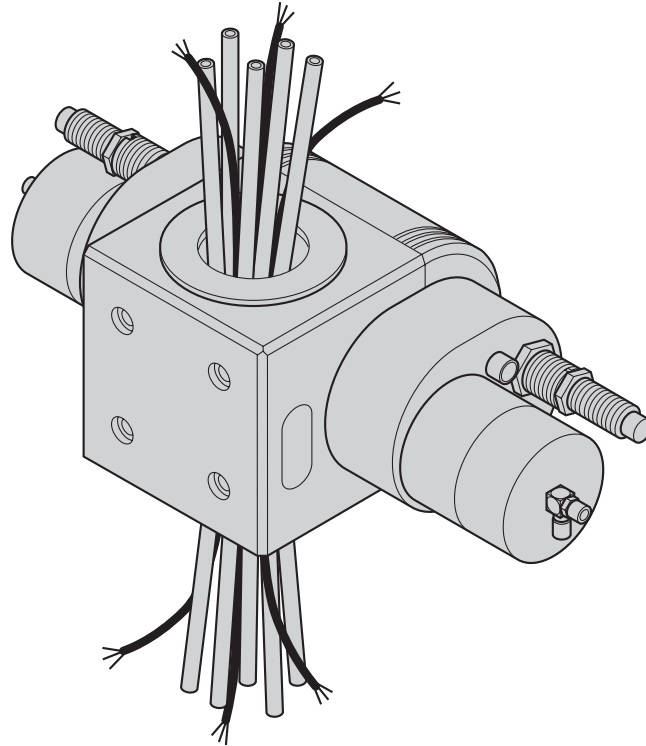

## Compressed air input

Fig. 10

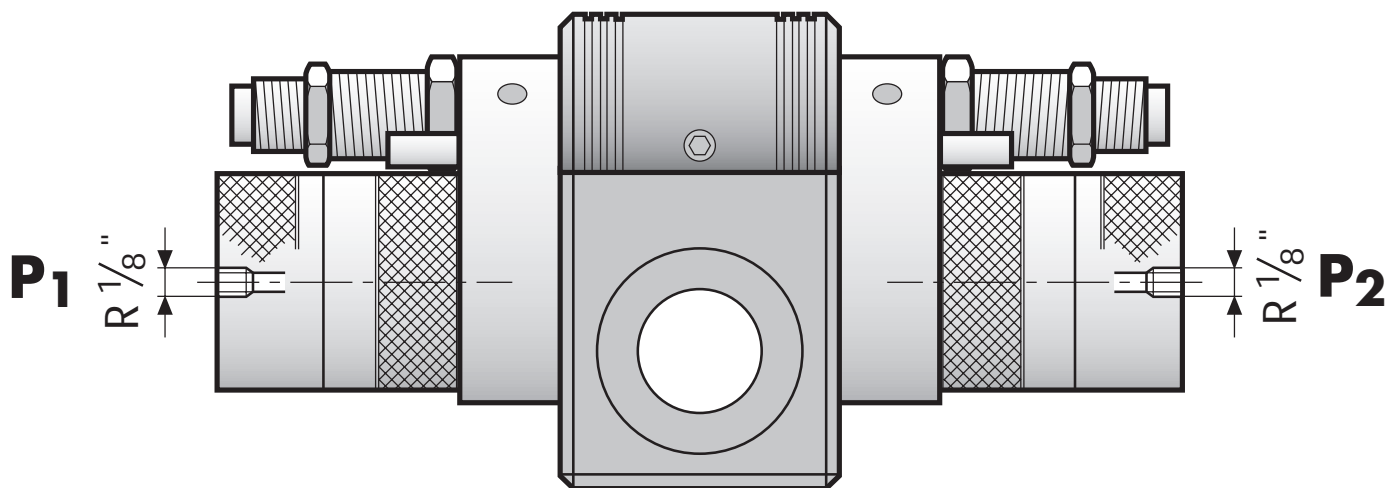

**P<sub>1</sub>** ... Turning clockwise

**P<sub>2</sub>** ... Turning anticlockwise

**Setting the angle of rotation  $\varphi$**  (see Fig.20)

The angle of rotation has to be set using a very low speed of rotation. The non-return throttle valves (440) therefore should be opened by only 2-3 turns.

- Release the lock-nut (170).
- Turning one or both of the stop bushes (120) alters the angle of rotation (1 turn = appr.  $3.5^\circ$ ). The stop bushes may only be moved in the unloaded state.
- Tighten the lock-nut (170).
- When the stop bushes (120) are turned back fully, a maximum angle of rotation  $\varphi$  of 180 is obtained.

### **Setting the shock-absorbers** (see Fig.20)

The speed of travel, the mass moment of inertia, the operating pressure and, in certain cases, the position of the axis of rotation, influence the amount of energy to be absorbed by the shock-absorbers. The optimum setting of the shock-absorbers, i.e. that which results in the shortest travel time for given variables, is obtained as follows.

- Mount the rotary unit in the desired position.
- From the fully closed position open the non-return throttle valves (440) about 2-3 turns.
- Release the lock-nut of the shock-absorber.
- Screw the shock-absorber (220) into the stop bush (120) until the set angle of rotation  $\varnothing$  begins to decrease.
- Increase the speed of travel by opening the non-return throttle valve (440) until the rotating mass moves into the appropriate end position apparently with constant speed, without causing any impact.

If this point is not attained, even with the throttle fully open, i.e. if a reduction in speed is apparent just before the end position is reached, the shock-absorber must be slowly turned back until the end position is approached without any apparent speed reduction.

In rooms with fluctuating ambient temperature this setting must be carried out at the highest temperature that occurs.

- Tighten the lock-nut of the shock-absorber.

### **Setting and connecting the inductive proximity switches**

The inductive proximity switches may not be set until the angle of rotation has been determined and no longer changes.

The proximity switches used must possess a switching distance ( $S_n$ ) of 1 - 2 mm, be designed for flush mounting and have a casing M8x1 in diameter.

Adjustment

Fig. 11

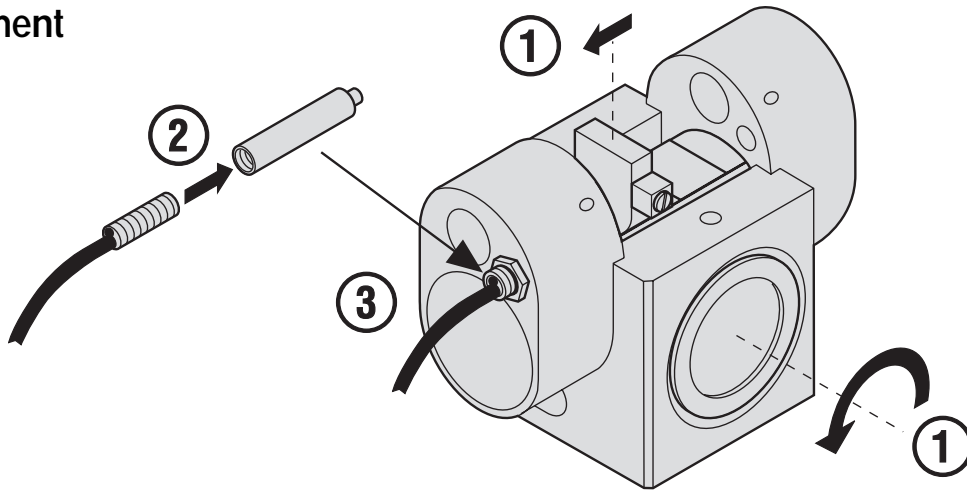
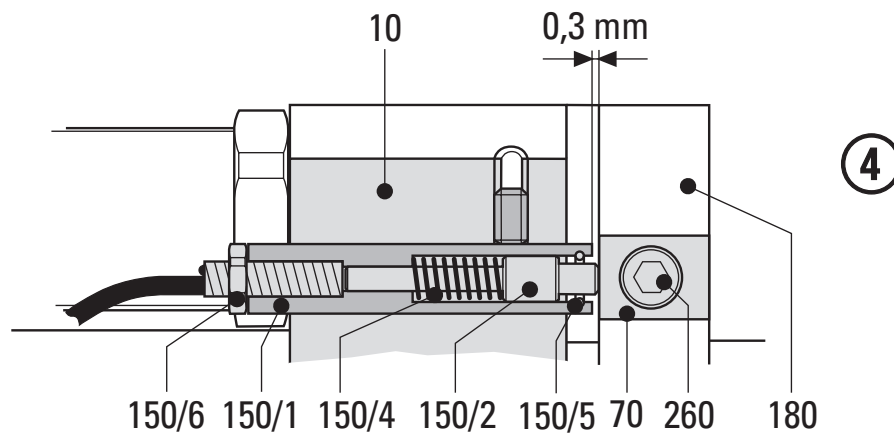
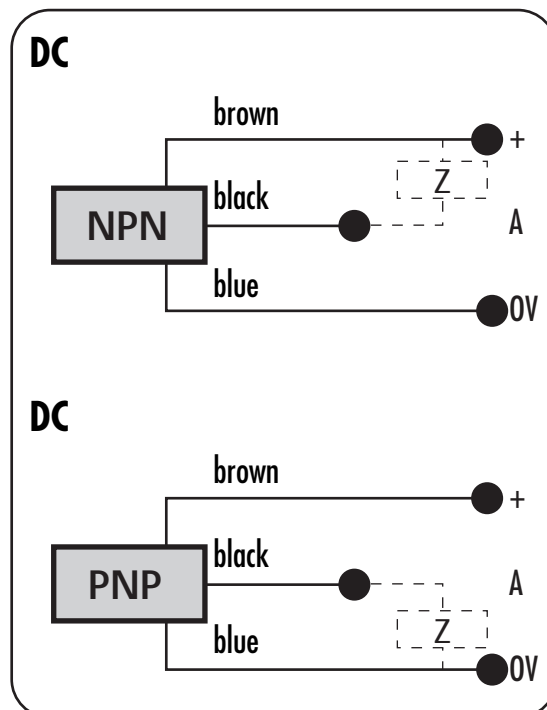

Fig. 12



The inductive proximity switch is dismantled by removing the hexagon nut (150/6).

Fig. 13

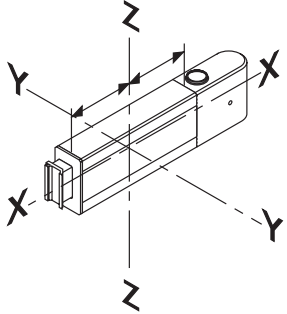

## Technical data of MONTECH standard components

Component	Type	Weight kg	Moment of inertia (kg cm <sup>2</sup> )			Remarks
			J <sub>x</sub>	J <sub>y</sub>	J <sub>z</sub>	
Linear units	LEP-60-1A	2,2	30	227 1)	212 1)	Fig. 14 
	LEP-60-1B	2,6	35	316 1)	297 1)	
	LEP-90-1A	2,5	34	304 1)	286 1)	
	LEP-90-1B	3,1	42	492 1)	470 1)	
	LEP-160-1A	3,2	43	535 1)	513 1)	
	LEP-160-1B	3,8	51	837 1)	810 1)	
	LEP-225-1A	4,6	62	1580 1)	1546 1)	
	LEP-225-1B	4,7	63	1615 1)	1580 1)	
	LEP-320-2A	8,0	108	3570 1)	3450 1)	
	LEP-320-2B	9,6	130	5500 1)	5360 1)	
	LEP-450-2A	10,5	142	7940 1)	7780 1)	
	LEP-450-2B	11,1	150	8390 1)	8230 1)	
	Slides	US(L)-20-1 2)	0,68	3,1	13,4	
US(L)-30-1 2)		0,72	3,2	18	21	
US(L)-40-1 2)		0,77	3,5	24	27	
US(L)-40-2 2)		0,96	6,0	30	35	
US(L)-60-2 2)		1,04	6,4	47	52	
US(L)-80-2 2)		1,14	7,1	71	76	
US(L)-60-3 2)		1,56	13,2	71	81	
US(L)-90-3 2)		1,82	15,4	131	142	
US(L)-120-3 2)		2,06	18	214	227	
US(L)-80-4		2,68	31	253	277	
US(L)-120-4		3,06	35	441	469	
US(L)-160-4		3,48	40	712	744	
US(L)-100-5		3,84	56	482	530	
US(L)-150-5		4,56	66	904	958	
US(L)-200-5		5,24	76	1510	1570	
US(L)-120-6		5,48	105	869	957	
US(L)-180-6		6,58	127	1700	1800	
US(L)-240-6		7,66	147	2920	3040	

1) J<sub>y</sub> and J<sub>z</sub> only apply when the slide is retracted.

2) Also applies to USE slides.

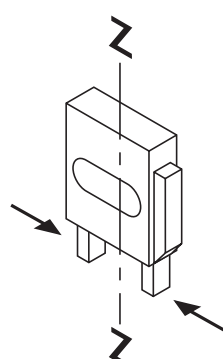
Component	Type	Weight kg	Moment of inertia $J_z$ (kg cm <sup>2</sup> )	Remarks
Gripper	GPP-1/GPPI-1	0.25/0.26	0.87	<p>Fig. 16</p> 
	GPP-2/GPPI-2	0.68/0.68	4.3	
	GPP-3/GPPI-3	1.32/1.42	14.0	
	GS-1/GSI-1	0.16/0.17	*	
	GS-2/GSI-2	0.32/0.31	1.0	
	GK-1/GKI-1	0.22/0.22	0.41	
	GPS-1/GPSI-1	0.08/0.09	*	
	GPS-2/GPSI-2	0.15/0.16	*	
	GPS-3/GPSI-3	0.35/0.36	0.84	
	GPS-4/GPSI-4	0.59/0.60	2.15	
	GW-1/GWI-1	0.24	0.5	
	GW-2/GWI-2	0.4	1.25	
Quick-Set	SLL-12	0.011	*	
	SLL-20	0.020	*	
	SLL-55	0.056	*	
	SLR-15	0.070	*	
	SRR	0.070	*	
	KW	0.220	*	

\*  $J$  can be neglected for calculation, but not  $m * p^2$  or  $m * q^2$

## Formulas for calculating moments of inertia

Cylinder (Fig. 17)

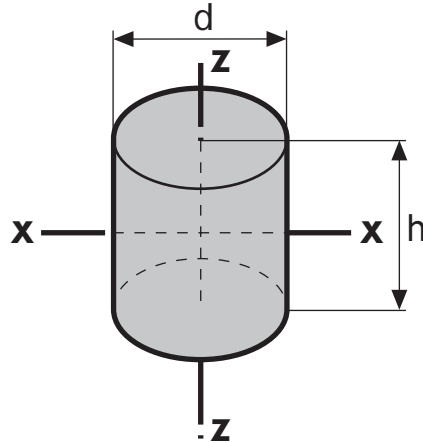

$$J_x = \frac{1}{16} * m * (d^2 + \frac{4}{3} h^2)$$

$$J_z = \frac{1}{8} * m * d^2$$

Cube (Fig. 18)

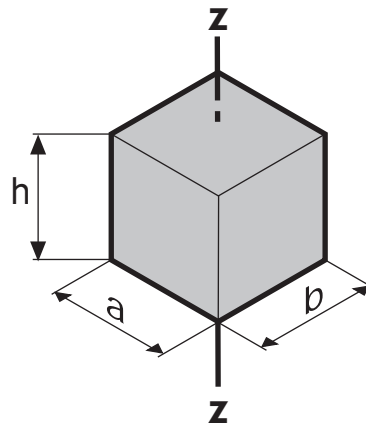

$$J_z = \frac{1}{12} * m * (a^2 + b^2)$$

Mass outside the axis of rotation (Fig.19)

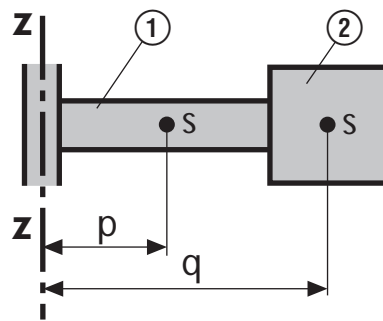

$$J_{①/②} z-z =$$

$$J_{①} + m_{①} * p^2 + J_{②} + m_{②} * q^2$$

- Jx-x = Moment of inertia with axis of rotation x-x (kgcm<sup>2</sup>)
- Jz-z = Moment of inertia with axis of rotation z-z (kgcm<sup>2</sup>)
- m = Mass (kg)
- a = Length (cm)
- b = Width (cm)
- d = Diameter (cm)
- h = Height (cm)
- s = Centre of gravity of mass ① or ②
- p = Distance of mass ① from axis of rotation (cm)
- q = Distance of mass ② from axis of rotation (cm)

## Maintenance

### Inspecting the shock-absorbers

All standard equipment from MONTECH contain shock-absorbers of premium quality. Nevertheless the failure of a shock-absorber cannot be entirely ruled out.

We therefore recommend that during operation attention should be paid to the rotating masses; to ensure that they do not move into their end position with a sharp impact. Where this does happen, the affected shock-absorber must be immediately readjusted in accordance with “Setting the shock-absorbers”. If a satisfactory result is not obtained, the shock-absorber will have to be replaced.

**Note:** Defective shock-absorbers appreciably shorten the useful life of the rotary units. Accuracy and repeatability of the end positions are then no longer assured.

DAP-3 is generally maintenance-free up to 10 Mio cycles. We recommend the following preventative maintenance to ensure optimum performance of the unit:

- Periodic cleaning of the unit, particularly the mechanical guide.
- Inspection of the seals, possible replacement
- Lubricate with Paraliq P460 (Montech article no. 504721), particularly the mechanical guide

Lubrication is via grease nipple ( Fig. 20, 530) on the plate (Fig. 19, 60). To reach the lubrication nipple (Fig. 20, 530), first remove the cover (Fig. 20, 130) by undoing the machine screw (Fig. 20, 270a).

For further information about our services, support and downloads, please visit our homepage at [www.montecom.com](http://www.montecom.com) or contact your local representative.



When the cover is removed (Fig. 20, 130) there is a danger of contusion injury! After lubrication reinstall the cover (Fig. 20, 130).

**DAP-3** (Fig. 20)

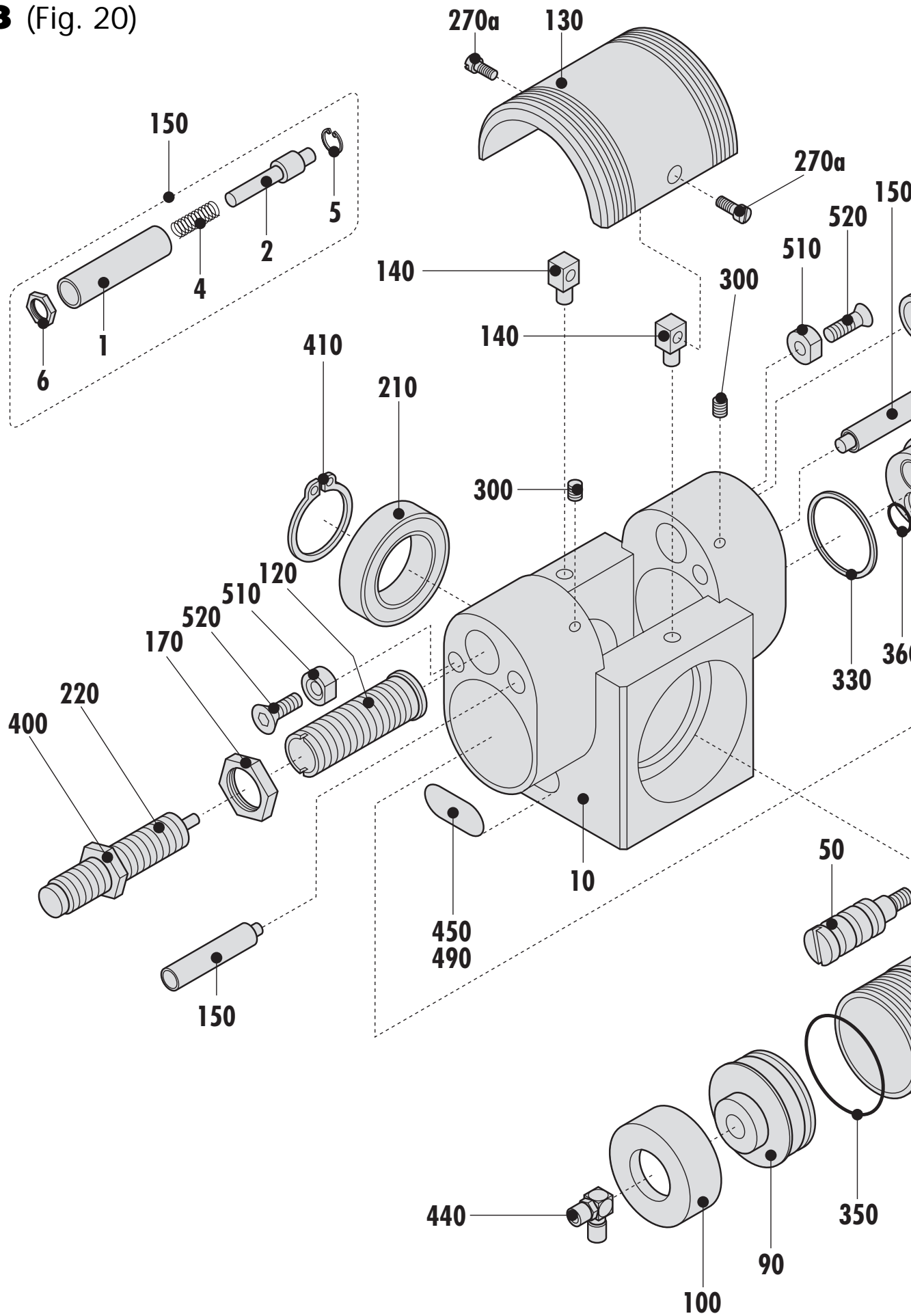

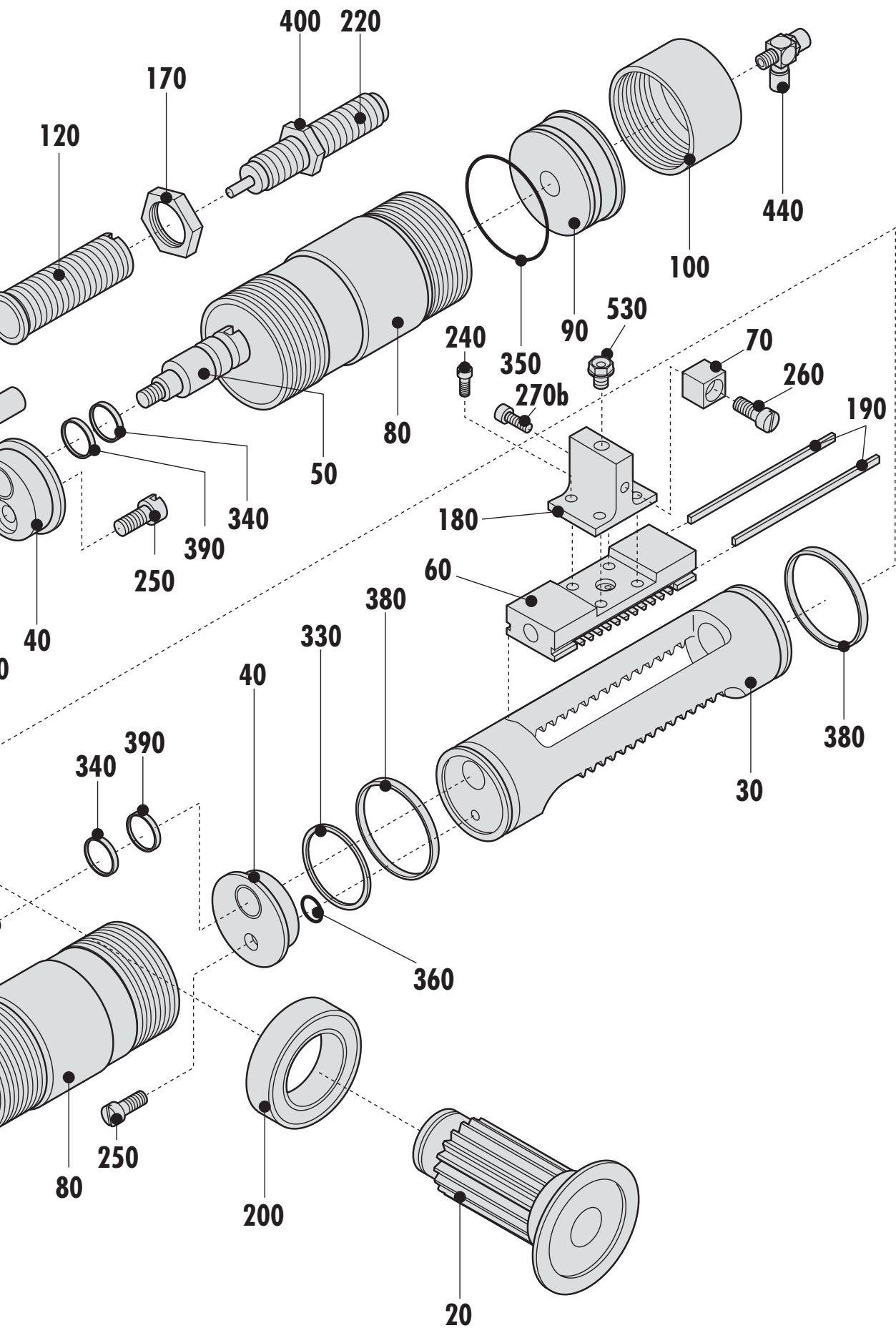

## Spare parts list

<b>No.</b>	<b>Part</b>	<b>Ref.No.</b>	<b>Supplier</b>	<b>Material</b>
10	Housing	45056	Montech AG	Aluminium
20*	Pinion shaft	45057	Montech AG	Steel
30*	Toothed piston	45059	Montech AG	Steel
40	Cover	45063	Montech AG	POM
50	Guide pin	45062	Montech AG	Stainless steel
60*	Rack bar	48727	Montech AG	Steel
70	Cube	45068	Montech AG	Steel
80	Cylindrical tube	48359	Montech AG	Stainless steel
90	Cover	45064	Montech AG	Aluminium
100	Skirted nut	45065	Montech AG	Aluminium
120	Stop bush	48005	Montech AG	Steel
130	Cover	45070	Montech AG	POM
140	Link	45069	Montech AG	Steel
150	Damping pin	45550	Montech AG	POM/Steel
170	Nut	45083	Montech AG	Steel
180	Link	48728	Montech AG	Steel
190	Greasing felt	48729	Montech AG	Wool felt
200	Grooved ball bearing	505164	6012.2ZR	Steel
210	Grooved ball bearing	505165	6009.2ZR	Steel
220*	Shock-absorber	506068	Montech AG	Steel
240	Chhd screw	501637	M5 x 10	Steel
250	Chhd screw	504644	M6 x 12	Stainless steel
260	Chhd screw	501658	M6 x 16	Steel
270	Chhd screw	501654	M6 x 8	Steel
300	Set-screw	501924	M6 x 10	Steel
330*	Piston gasket	505170	Angst + Pfister AG	NBR
340*	Piston gasket	504972	Angst + Pfister AG	NBR
350*	O-ring	505168	Busak+Shamban AG	NBR
360*	O-ring	504829	Busak+Shamban AG	NBR
380	Guide ring	505172	Busak+Shamban AG	P.T.F.E

<b>No. Part</b>	<b>Ref.No.</b>	<b>Supplier</b>	<b>Material</b>
390* Guide ring	505173	Busak+Shamban AG	P.T.F.E
400 Hex nut	505174	Montech AG	Steel
410 Circlip	502464	Bossard AG	Steel
440 Non-return throttle valve	505016	SMC Pneum. AG	Steel
450 Nameplate	41620	Montech AG	metall.polyester
460 Operating instructions	507268	Montech AG	Paper
490 Clear cover	48508	Montech AG	PU
510 Support (Cylindrical tube)	48620	Montech AG	POM black
520 Screw (spec.)	48621	Montech AG	Stainless steel
530 Lubricating nipple	504554	Hausammann AG	Steel
540 Dummy plug	502670	Bossard AG	Low density polyethylene

\*All this articles are available as spare parts.

### **Environmental Compatibility**

#### **Materials used**

- Aluminium
- Steel
- Acrylnitrile-Butadiene rubber (NBR as per ISO 1629)
- POM Polyoxymethylene (Polyacetal)
- P.T.F.E.
- Paraffinic mineral oil, synthetic hydrocarbon oil
- PU
- Wool felt

#### **Surface finish**

- Anodized aluminium
- Blackened steel
- Varnished POM

#### **Shaping processes**

- Machining of Al, steel, POM, PTFE
- Moulding NBR gaskets

#### **Emissions while in operation**

- None

When the equipment is operated with oiled air we recommend returning the exhaust to atmosphere through an oil filter or separator.

#### **Disposal**

Rotary units which are no longer fit for service should not be disposed of as complete units, but stripped down to their components, which can then be recycled according to the material they contain. The materials used for the components is shown in the list of spare parts. Materials which cannot be recycled should be disposed of appropriately.



MONTECH AG  
Gewerbestrasse 12, CH-4552 Derendingen  
Fon +41 32 681 55 00, Fax +41 32 682 19 77  
info@montech.com, www.montech.com